

# **LASER MEASUREMENT SYSTEM**

## **5526A**

### **SERVICE HANDBOOK SUPPLEMENT**

#### **FOR**

### **STRAIGHTNESS INTERFEROMETERS**

#### **5526A OPTIONS 030, 031, and 032**

This handbook supplement applies directly to Hewlett-Packard Model 10690A and 10691A Straightness Interferometers, and to 10579A Straightness Adapters with 10579-60004 Resolution Extenders having the Serial Prefix 1328A. For later revisions, a change sheet is included with this supplement.

Copyright      HEWLETT-PACKARD COMPANY      1973  
5301 STEVENS CREEK BLVD., SANTA CLARA, CALIF. 95050

Printed: NOV 1973

Manual Part No. 05526-90021  
Manual Microfiche No. 05526-90025

PRINTED IN U.S.A.

HEWLETT  PACKARD

## **CERTIFICATION**

*The Hewlett-Packard Company certifies that this instrument was thoroughly tested and inspected and found to meet its published specifications when it was shipped from the factory. The Hewlett-Packard Company further certifies that its calibration measurements are traceable to the U.S. National Bureau of Standards to the extent allowed by the Bureau's calibration facility.*

## **WARRANTY**

This Hewlett-Packard product is warranted against defects in material and workmanship for a period of 90 days from date of shipment. Hewlett-Packard will repair or, at its option, replace, without charge, any parts which prove to be defective during the warranty period. Warranty service will be performed on-site at the customer's facility in the United States, Canada, Western Europe and in other countries near designated Hewlett-Packard service facilities, provided that the customer's facilities are accessible and regularly served by suitable public transportation.

**NO OTHER WARRANTIES ARE EXPRESSED OR IMPLIED, INCLUDING BUT NOT LIMITED TO, THE IMPLIED WARRANTIES OF MERCHANTABILITY AND FITNESS FOR A PARTICULAR PURPOSE. HEWLETT-PACKARD IS NOT LIABLE FOR CONSEQUENTIAL DAMAGES.**

## **SAFETY PRECAUTIONS**

### **WARNING**

#### **LASER BEAM**

This instrument emits laser light. The power output of the HP laser is low in comparison to most other lasers, either continuous wave or pulsed, but due to the high brilliance factor, the output beam of any laser should never be allowed to strike the eye directly. It is the considered opinion of Hewlett-Packard Company that the light beam from this device presents NO hazard to health and safety. However, the existence of newly enacted federal regulations with respect to laser devices together with the lack of any widely accepted standards of laser power safety thresholds requires the insertion of this cautionary statement.

### **WARNING**

#### **HIGH VOLTAGE**

High voltages are generated within the laser housing. The cover of the Model 5500C Laser is provided with an interlock to prevent accidental access to these voltages. There are no high voltages on the interconnecting cable however, should it become cut or disconnected.

### **CAUTION**

The Straightness Interferometer and Straightness Reflector have precision ground and accurately lapped external surfaces. For best performance, keep the mechanical and optical surfaces clean.

**TABLE OF CONTENTS**

Section		Page
I	GENERAL INFORMATION .....	1-1
	1-1. Introduction .....	1-1
	1-3. 5526A Option 030 Straightness Interferometer (Short Range) .....	1-1
	1-5. 5526A Option 031 Straightness Interferometer (Long Range) .....	1-1
	1-7. 5526A Option 032 Straightness Interferometer (Full Range) .....	1-1
	1-9. 5526A Laser Measurement Systems and Its Publications .....	1-1
	1-11. Instrument Identification .....	1-1
	1-13. Specifications .....	1-2
II	INSTALLATION AND OPERATION .....	2-1
	2-1. Introduction .....	2-1
	2-3. Unpacking and Installation .....	2-1
	2-5. Installation .....	2-1
	2-7. Optical System Alignment .....	2-1
	2-9. Operation .....	2-2
III	THEORY OF OPERATION .....	3-1
	3-1. Introduction .....	3-1
	3-3. Functional Description .....	3-1
	3-12. Logic Elements .....	3-3
	3-16. Integrated Circuits .....	3-4
	3-18. Quadruple 2-Input Nand Gate (1820-0054) .....	3-4
	3-20. Dual D-Type Edge-Triggered Flip-Flop (1820-0077) .....	3-5
	3-22. Operational Amplifier (1820-0216) .....	3-5
	3-24. J-K Flip-Flop (1820-0304) .....	3-6
	3-26. Quadruple 2-Input Nor Gate (1820-0328) .....	3-7
	3-28. Dual Monostable Multivibrator (1820-0515) .....	3-7
	3-30. Dual Voltage-Controlled Mutivibrator (1820-0567) .....	3-8
	3-32. Phase-Frequency Detector (1820-0630) .....	3-8
	3-35. Dual Differential Line Driver (1820-0720) .....	3-9
	3-37. Dual Line Receiver (1820-0721) .....	3-10
	3-39. Presettable Decade Counter/Latch (1820-0751) .....	3-10
IV	MAINTENANCE .....	4-1
	4-1. Introduction .....	4-1
	4-3. Test Equipment .....	4-1
	4-5. Functional Checks .....	4-1
	4-7. Functional Check with Straightness Measuring Optics .....	4-1
	4-9. Functional Check with Distance Measuring Optics .....	4-2
	4-11. Adjustment Procedure .....	4-2
	4-13. Adjustment with 5526A Laser Measurement System .....	4-2
	4-15. Adjustment Without 5526A Laser Measurement System .....	4-3
	4-17. Troubleshooting .....	4-3
V	REPLACEABLE PARTS .....	5-1
	5-1. Introduction .....	5-1
	5-4. Ordering Information .....	5-1

**LIST OF FIGURES**

Figure		Page
1-1.	10579A Straightness Adapter .....	1-0
1-2.	10690A and 10691A Straightness Interferometers .....	1-0
3-1.	Functional Block Diagram of HP 10579-60004 Resolution Extender .....	3-2
3-2.	Logic Comparison Diagrams .....	3-3
3-3.	Gate Symbols .....	3-4
3-4.	Quadruple 2-Input Nand Gate .....	3-4
3-5.	Dual D-Type Edge-Triggered Flip-Flop .....	3-5
3-6.	Operational Amplifier .....	3-5
3-7.	J-K Flip-Flop .....	3-6
3-8.	Quadruple 2-Input Nor Gate .....	3-7
3-9.	Dual Monostable Multivibrator .....	3-7
3-10.	Dual Voltage-Controlled Multivibrator .....	3-8
3-11.	Phase-Frequency Detector .....	3-9
3-12.	Dual Differential Line Driver .....	3-9
3-13.	Dual Line Receiver .....	3-10
3-14.	Presetable Decade Counter/Latch .....	3-11
4-1.	Functional Test With Straightness Optics .....	4-0
4-2.	Functional Test With Distance Optics .....	4-0
4-3.	Troubleshooting Procedure .....	4-4
4-4.	A1 Frequency Multiplier Schematic Diagrams .....	4-5
4-5.	Rear-Panel Connector Assembly Schematic Diagram .....	4-7

**LIST OF TABLES**

Table		Page
4-1.	Recommended Test Equipment .....	4-1
5-1.	Replaceable Parts .....	5-1
5-2.	Manufacturers Code List .....	5-4

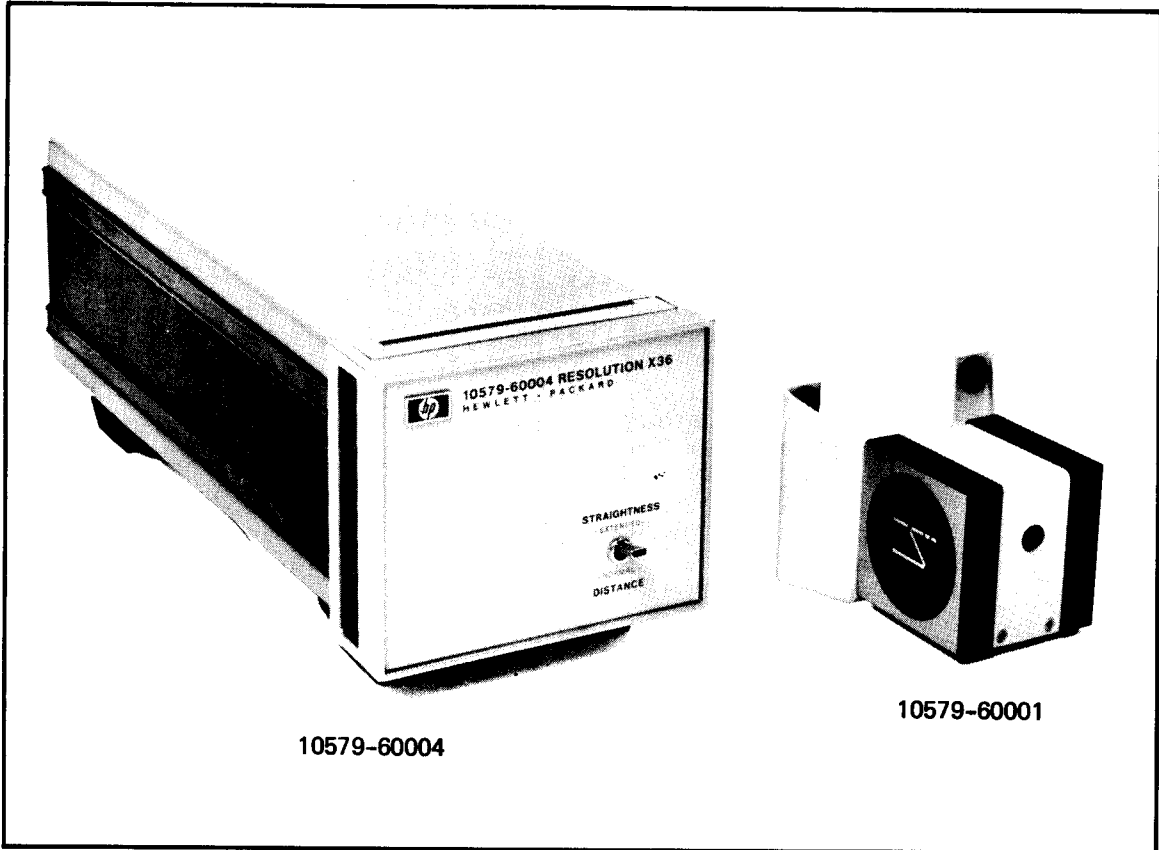

Figure 1-1. 10579A Straightness Adapter

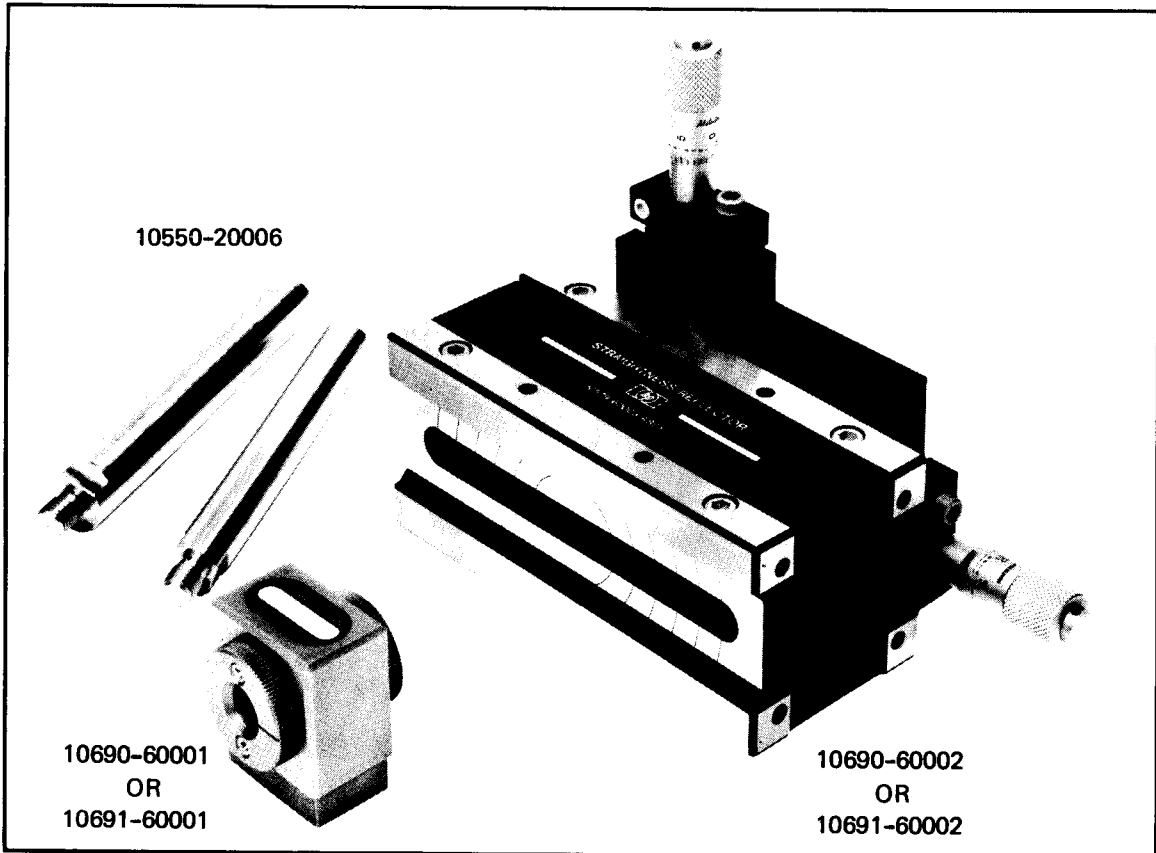

Figure 1-2. 10690A and 10691A Straightness Interferometers

## SECTION I

### GENERAL INFORMATION

#### 1-1. INTRODUCTION

1-2. This publication is a supplement to the basic 5526A Laser Measurement System Service Handbook, and should be placed in the Service Handbook three-ring binder. This supplement contains the servicing information required for the Model 10579A Straightness Adapter illustrated in Figure 1-1.

#### 1-3. 5526A OPTION 030 STRAIGHTNESS INTERFEROMETER (SHORT RANGE)

1-4. The Hewlett-Packard Model 5526A Option 030 consists of a 10579A Straightness Adapter and a 10690A Short-Range Straightness Interferometer (Figure 1-2). It permits measurements over the range of 4 inches (100 mm) to 10 feet (3m).

#### 1-5. 5526A OPTION 031 STRAIGHTNESS INTERFEROMETER (LONG RANGE)

1-6. The Hewlett-Packard Model 5526A Option 031 consists of a 10579A Straightness Adapter and a 10691A Long-Range Straightness Interferometer. It permits measurements over the range of 3 feet (1m) to 100 feet (30m).

#### 1-7. 5526A OPTION 032 STRAIGHTNESS INTERFEROMETER (FULL RANGE)

1-8. The Hewlett-Packard Model 5526A Option 032 consists of a 10579A Straightness Adapter, a 10690A Short-Range Straightness Interferometer, and a 10691A Long-Range Straightness Interferometer. It permits straightness measurements over both ranges.

#### 1-9. 5526A LASER MEASUREMENT SYSTEM AND ITS PUBLICATIONS

1-10. The basic 5526A system and all standard options are described in separate publications. A current listing of publications about the 5526A Laser Measurement System is available from the following address:

HEWLETT-PACKARD  
5301 Stevens Creek Boulevard  
Santa Clara, California 95050  
United States of America  
*Attention: Laser Publications*

#### 1-11. INSTRUMENT IDENTIFICATION

1-12. Each Hewlett-Packard instrument has a 10-character serial number (e.g., 0000A00000). The first four digits form a serial prefix that identifies a group of identical instruments, and the last five digits form a serial number that is unique for each instrument. If the serial prefix of your instrument is not on the title page of this manual, your instrument is different from the one described in this manual and a manual change sheet is included to describe the difference. If the manual change sheet is missing, request one from the nearest Hewlett-Packard Sales and Service Office.

### 1-13. SPECIFICATIONS

1-14. The Option 30 Series Straightness Interferometers retain all specifications of the 5526A Laser Measurement System with the following exceptions:

**Maximum Measuring Velocity:** The maximum measuring velocity limitations apply to lateral velocity only. Higher longitudinal velocities (parallel to laser axis) may be used.

**Resolution:** System resolution is reduced when the Long-Range Straightness Interferometer is used. Refer to specifications in the following paragraph.

1-15. Unless otherwise stated, the following specifications apply to both the Short-Range and Long-Range Straightness Interferometers:

#### ACCURACY:

Inch:  $\pm 5$  microinches/foot  $\pm 1$  count in last digit.

Metric:  $\pm 0.4$  micrometer/meter  $\pm 2$  counts in the last digit.

*Note: This accuracy can be improved to the limit of linearity by rotating the Straightness Reflector through 180 degrees and making a second pass (equivalent to reversal of a straightedge).*

#### LINEARITY:

Inch:  $\pm 1$  count in last digit.

Metric:  $\pm 2$  counts in last digit.

#### CALIBRATION:

Short Range:  $\pm 5\%$  of reading.

Long Range:  $\pm 10\%$  of reading.

*Note: The actual calibration value is marked on each Straightness Reflector. This value is valid only for reflectors and interferometers having matching serial numbers.*

#### RESOLUTION:

Short Range: As for 5526A Laser/Display.

Long Range: One-tenth that of the short-range version; e.g., in the X10 Mode, Metric units, the last digit has a value of 0.1 micrometer; in the NORMAL mode, Inch units, the last digit has a value of 0.0001 inch.

#### AXIAL RANGE:

Short Range: 10 feet (3m)  $\pm 5\%$ .

Long Range: 100 feet (30m)  $\pm 10\%$ .

*Note: The minimum distance between the Straightness Interferometer and the Straightness Reflector at which measurements can be made are:*

*Short Range: 4 inches (100 mm)*

*Long Range: 3 feet (1m)*

#### LATERAL RANGE:

$\pm 0.1$  inch (2.5 mm)

#### WEIGHTS:

10579A: Straightness Adaptor 1.0 lb. (0, 45 Kg)

Resolution Extender 1.8 lb. (0, 82 Kg)

10690A: Straightness Reflector 3.5 lb. (1, 63 Kg)

Straightness Interferometer 0.5 lb. (0, 23 Kg)

10691A: Straightness Reflector 3.5 lb. (1, 63 Kg)

Straightness Interferometer 0.5 lb. (0, 23 Kg)



**DIMENSIONS:**

**Straightness Interferometer Assembly**

Height: 1.250 inches (31, 75 mm)  
Width: 1.250 inches (31, 75 mm)  
Depth: 1.250 inches (31, 75 mm)

**Straightness Reflector**

Height: 2.000 inches (50, 8 mm)  
Width: 4.500 inches (114, 30 mm)  
Depth: 2.000 inches (50, 8 mm)

**Straightness Adapter Assembly**

Height: 2.000 inches (50, 8 mm)  
Width: 2.000 inches (50, 8 mm)  
Depth: 2.000 inches (50, 8 mm)

**Resolution Extender**

Height: 4 inches (101, 6 mm)  
Width: 4.17 inches (105, 9 mm)  
Depth: 10.9 inches (276, 9 mm)



## SECTION II

### INSTALLATION AND OPERATION

#### 2-1. INTRODUCTION

2-2. This section provides installation and operating instructions for the 10579A Straightness Adapter.

#### 2-3. UNPACKING AND INSTALLATION

2-4. Prior to shipment, this equipment was inspected and met all specifications listed in Section I. Inspect the shipping container and, if damaged, remove and inspect all items. If any damage is discovered, file a claim with the carrier and notify the nearest Hewlett-Packard Sales and Service Office.

#### NOTE

If the 10579-60001 Straightness Adapter is not going to be mounted inside the 5500C Laser Head, it may be attached to the front of the Laser Head. However, a modification is necessary before this can be accomplished. The modification consists of removing four screws securing the front plate to the Laser Head, and installing four special mounting screws (HP P/N 10579-20001). The 10579-60001 Straightness Adapter Assembly can then be attached to and removed from the Laser Head without the use of tools. For inside mounting, refer to Operator's Handbook Supplement for Linear Interferometer, 5526A Option 010. Follow procedure described for Inside Mounting of Remote Interferometer.

#### 2-5. INSTALLATION

2-6. Installation consists of locating the 5500C Laser Head, 5505A Laser Display, and 10579-60004 Resolution Extender in suitable operating positions, connecting three cables, and aligning the optical system. Use the following procedure to connect the cables.

#### CAUTION

Electrical power must be off while connecting or disconnecting cables in the Laser Measurement System.

- a. Connect 05500-60025 cable between DISPLAY A connector on rear of 5500C Laser Head and LASER connector on rear of 10579-60004 Resolution Extender.
- b. Connect second 05500-60025 cable between DISPLAY connector on rear panel of 10579-60004 Resolution Extender and LASER connector on rear panel of 5505A Laser Display.
- c. Connect power cord between 5505A Laser Display and a suitable outlet.

#### 2-7. OPTICAL SYSTEM ALIGNMENT

2-8. If the optical system is to be mounted on a machine tool or a measuring machine, refer to the Optical System Alignment Procedure in the Operator's Handbook Supplement for Straightness Interferometers, 5526A Option 30 Series. If a quick setup is needed for functional testing

of the 10579-60004 Resolution Extender, refer to Functional Checks in Section IV of this handbook supplement.

## **2-9. OPERATION**

2-10. The 10579-60004 Resolution Extender can be operated in two modes. The NORMAL (DISTANCE) mode is used when making measurements of distance, flatness, pitch, yaw, or angles; all specifications of the basic 5526A Laser Measurement System are retained. The EXTENDED (STRAIGHTNESS) mode is used when measuring straightness or squareness. Changing from one mode to another will cause the RESET lamp on the 5505A Laser Display to flash.

## SECTION III

### THEORY OF OPERATION

#### 3-1. INTRODUCTION

3-2. This section contains a functional description of the 10579-60004 Resolution Extender, and describes the theory of operation of the integrated circuits used.

#### 3-3. FUNCTIONAL DESCRIPTION

3-4. The 10579-60004 Resolution Extender is used with the Straightness Interferometer options of the 5526A Laser Measurement System. When operated in the STRAIGHTNESS (EXTENDED) mode, it compensates for a scaling factor introduced by the optical arrangement and causes the 5505A Laser Display to indicate the actual deviation from a straight line. When operated in the DISTANCE (NORMAL) mode, the resolution extending circuits are bypassed and the laser measurement system operates in the distance measuring mode.

3-5. As shown in Figure 3-1, the Resolution Extender receives a beam alignment signal, a reference signal, and a Doppler signal from the 5500C Laser Head. In the DISTANCE (NORMAL) mode these signals simply pass through the resolution extender to the display, and the extender has no effect on normal operation of the system. In the STRAIGHTNESS (EXTENDED) mode, the beam alignment signal is amplified to compensate for the higher optical losses in the straightness adapter system and the Doppler frequency is multiplied by 36. A separate 2.5 MHz signal is generated by the extender to provide a fixed reference frequency for the 5505A Laser Display.

3-6. In the STRAIGHTNESS mode, the reference signal from the laser head passes through a line receiver to the reference mixer. The second input to the reference mixer is provided by the 2.5 MHz oscillator after its output frequency is divided by 36. The difference frequency out of the mixer is then divided by four to provide the reference input (TP4) to the phase detector.

3-7. The Doppler signal from the laser head passes through a separate line receiver to the Doppler mixer. This mixer is part of a phase-locked loop controlled by the phase detector. The output of the Doppler mixer is also divided by four to provide the second input (TP8) to the phase detector.

3-8. In order to understand the phase-locked loop, assume that there is no motion along the axis being measured. The reference and Doppler signals from the laser head would be equal in frequency. Under these conditions, the output frequency of the VCM (voltage-controlled multivibrator) makes the second input to the Doppler mixer (TP6) equal to the second input to the reference mixer (TP2). This makes the two inputs to the phase detector equal in frequency, and the reference and Doppler outputs to the display will also be equal in frequency. The latter condition is true only when the reference and Doppler signals are equal. Any deviation of the Doppler input signal is multiplied by a factor of 36 at the Doppler output.

3-9. With the reference frequency for the phase detector fixed, assume a movement along the measured axis that causes the Doppler input frequency to increase. This causes the Doppler mixer output at TP7 and the phase detector input at TP8 to start increasing in frequency. The leading phase of the Doppler input causes the phase detector to shift its dc output signal in the direction that increases the operating frequency of the VCM. The VCM frequency increases until the Doppler mixer input at TP6 has increased the same amount as the Doppler input at TP5. This action brings the phased-locked loop back into equilibrium, and the phase detector inputs at TP4 and TP8 will again be equal in frequency.

3-10. It should be noted that the VCM operating frequency is centered at twice the reference frequency, but its output is divided by two. For simplicity, the VCM output is assumed to be at TP9. The feature that actually causes a multiplication of the Doppler output frequency is the  $\times 36$  circuit in the feedback loop formed by part of U3, U4, and U5.

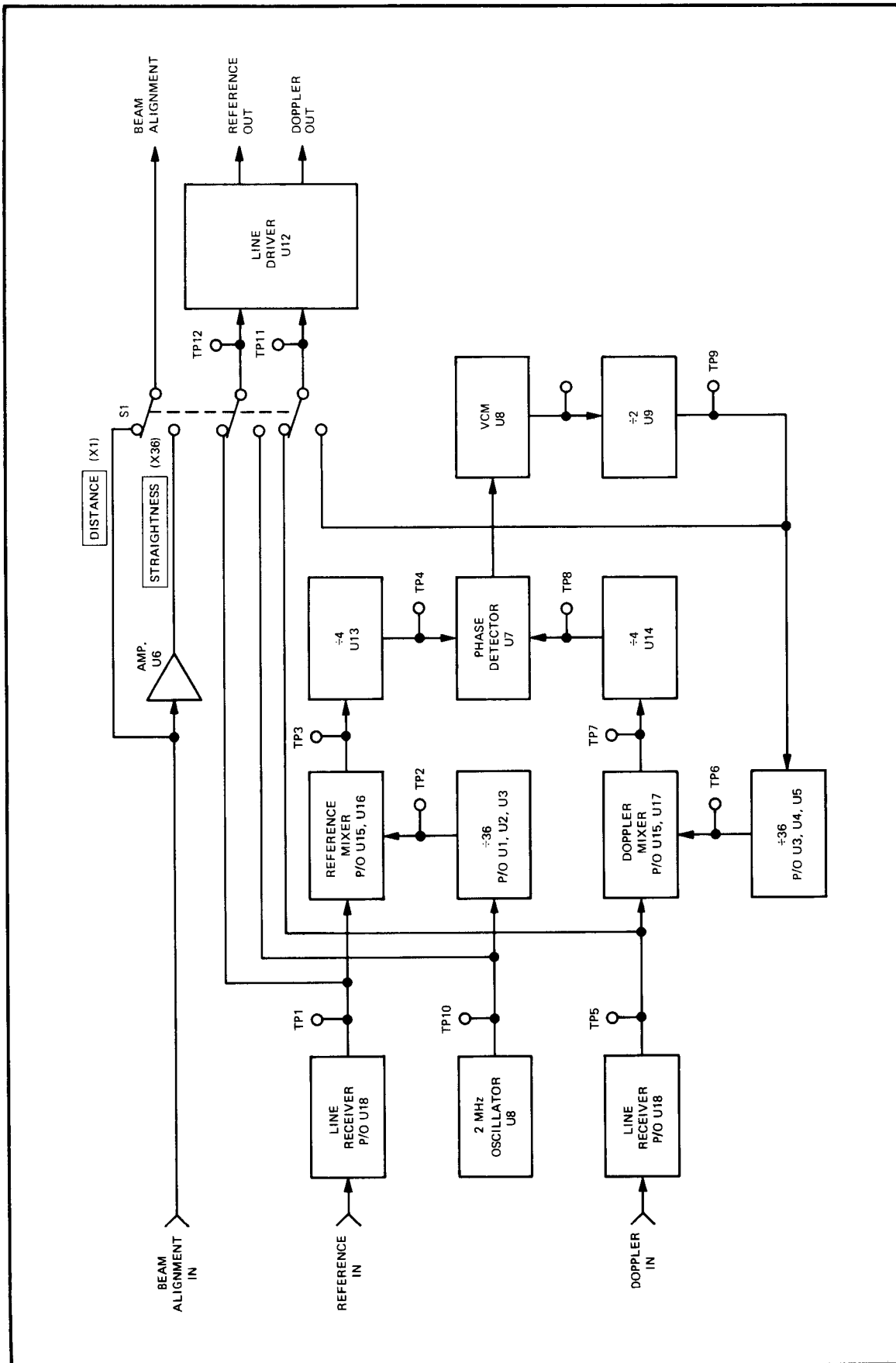

Figure 3-1. Functional Block Diagram of HP 10579-60004 Resolution Extender

3-11. As previously mentioned, a change in the Doppler frequency at TP5 must be matched by an equal change at TP6 to bring the phase-locked loop back into equilibrium. Since the Doppler mixer input at TP6 is 1/36th of the VCM output frequency (assumed at TP9), the VCM output frequency must shift 36 Hz for each 1 Hz shift in the Doppler input at TP5. This extended signal (TP9) is routed to a line driver to produce the Doppler output signal for the display unit.

### 3-12. LOGIC ELEMENTS

3-13. Two states exist in the binary system, 1 and 0. HIGH (H) and LOW (L) are used to represent the levels of 1 and 0. HIGH always represents the more positive level, whether it be positive or negative logic. Figure 3-2 shows four pairs of logic symbols that have the same truth tables and can be used interchangeably. The same function is performed by what appears to be two different logic symbols.

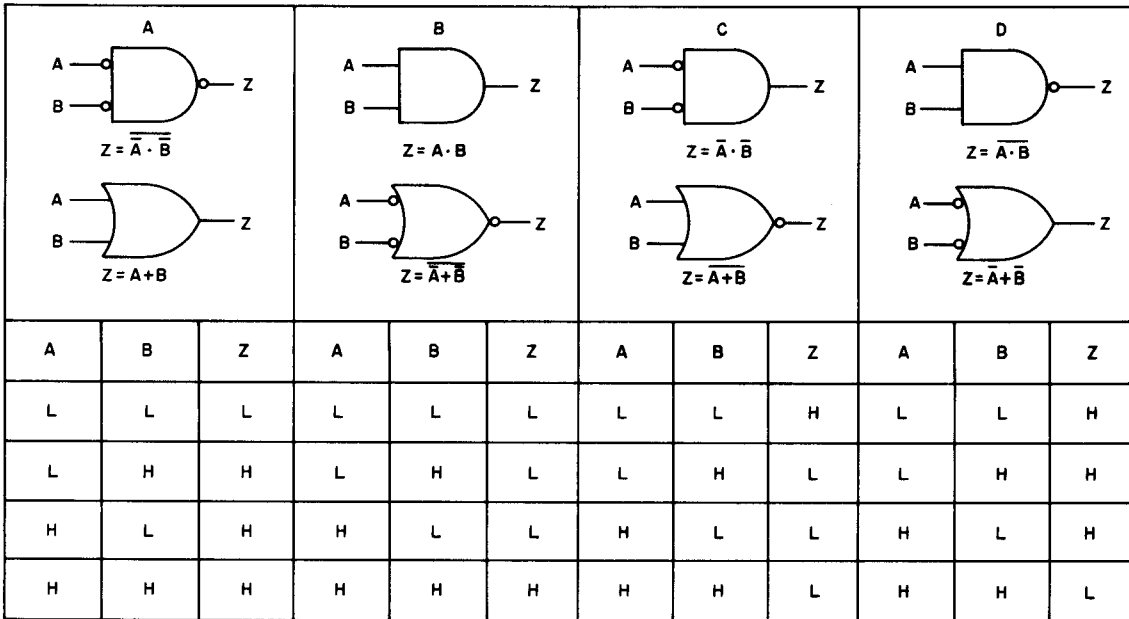

Figure 3-2. Logic Comparison Diagrams

3-14. Figure 3-3(A) represents a basic AND gate. The AND gate output is HIGH if all inputs are HIGH. An AND gate may have two or more inputs. Figure 3-3(B) represents a basic OR gate. The OR gate output is HIGH if one or more of its inputs is HIGH. An OR gate may have two or more inputs.

3-15. AND and OR gates are shown in Figure 3-3(A,B). A circle on the output of a logic symbol indicates a LOW when activated as shown in Figure 3-3(C,D). Thus, a circle indicates inversion. An AND gate with an inverted output is called a NAND gate; and OR gate with an inverted output is called a NOR gate. An amplifier with an inverted output is called an inverter, Figure 3-3(E).

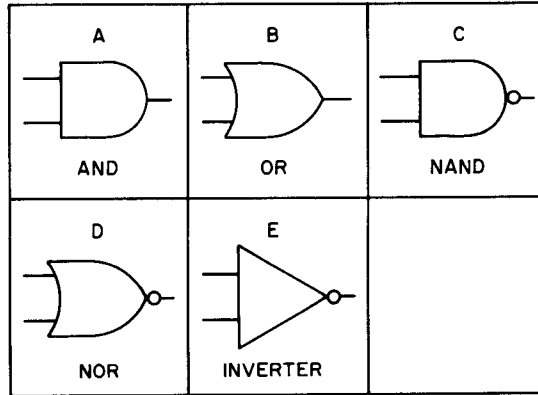

Figure 3-3. Gate Symbols

**3-16. INTEGRATED CIRCUITS**

3-17. The following paragraphs describe the integrated circuits used in the 10579-60004 Resolution Extender.

**3-18. Quadruple 2-Input Nand Gate (1820-0054)**

3-19. Figure 3-4 shows the logic diagram and truth table for the 1820-0054. Operation of the individual NAND gates is described in Paragraph 3-15.

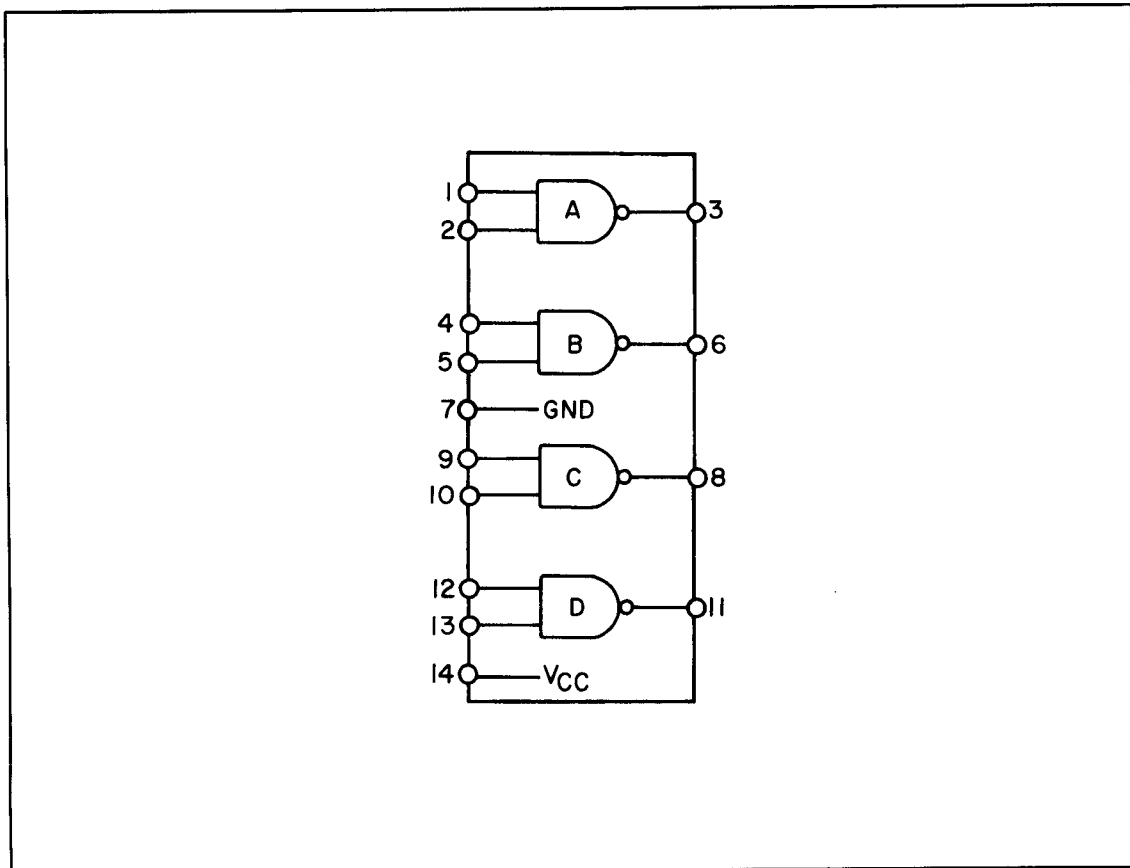

Figure 3-4. Quadruple 2-Input Nand Gate



**3-20. Dual D-Type Edge-Triggered Flip-Flop (1820-0077)**

3-21. Figure 3-5 shows the logic diagram, outline drawing, and truth table for the 1820-0077. As the truth table shows, the input data (D) is transferred to the output on the positive edge of the clock pulse. Clock triggering is determined by a voltage level of the clock pulse and is not directly related to the transition time of the positive-going pulse. After the clock input threshold level has been passed, the D input is locked out. A low at pin 4 or 10 will set the respective FF so the Q is high and  $\bar{Q}$  is low. A low at pin 1 or 13 will reset the flip-flop so that Q is low and  $\bar{Q}$  is high. The set and reset inputs will override all other inputs.

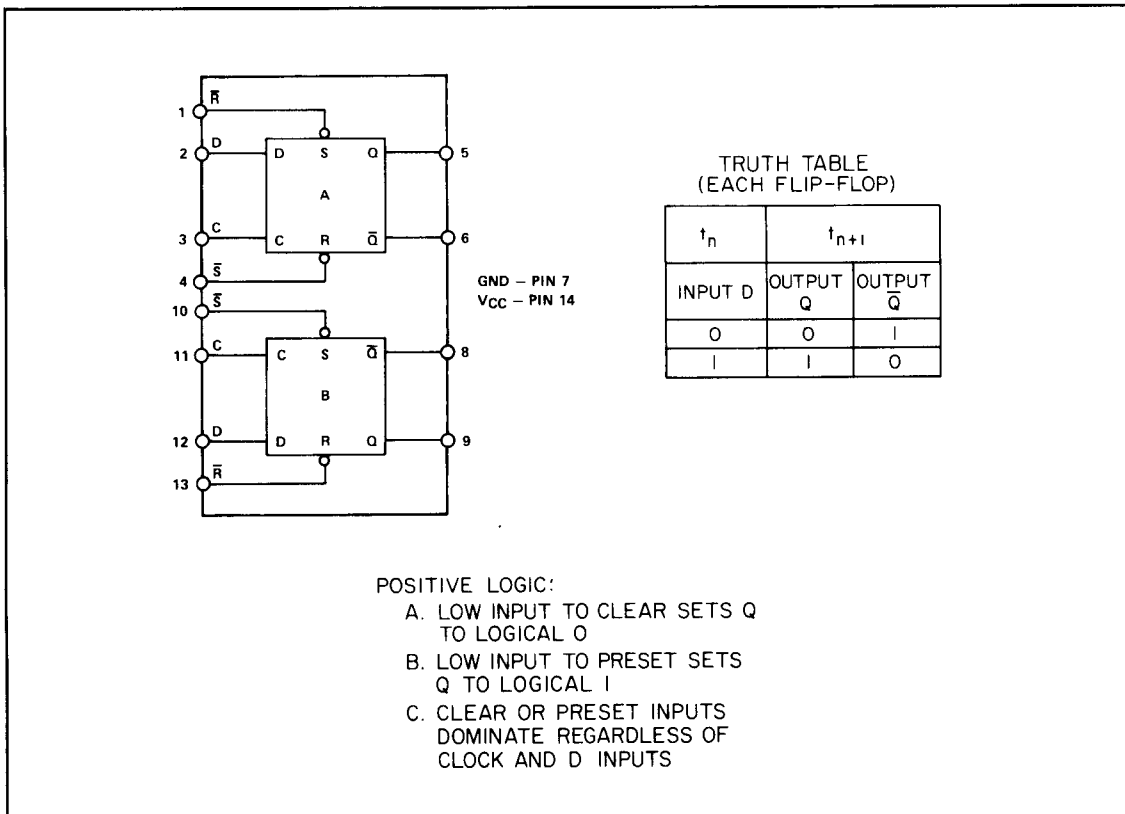

Figure 3-5. Dual D-Type Edge-Triggered Flip-Flop

**3-22. Operational Amplifier (1820-0216)**

3-23. Figure 3-6 shows the diagram of the 1820-0216 operational amplifier. In the 10597-60004 Resolution Extender, the feedback network is designed to provide a gain of approximately 1.5 for the Beam Alignment signal.

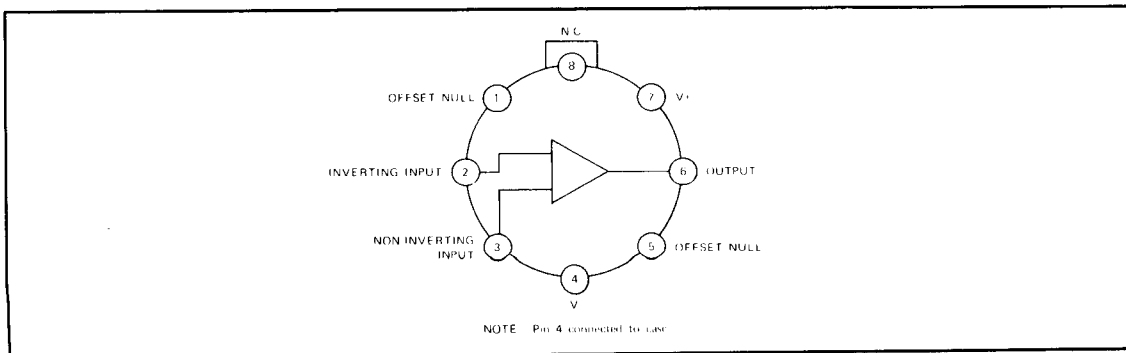
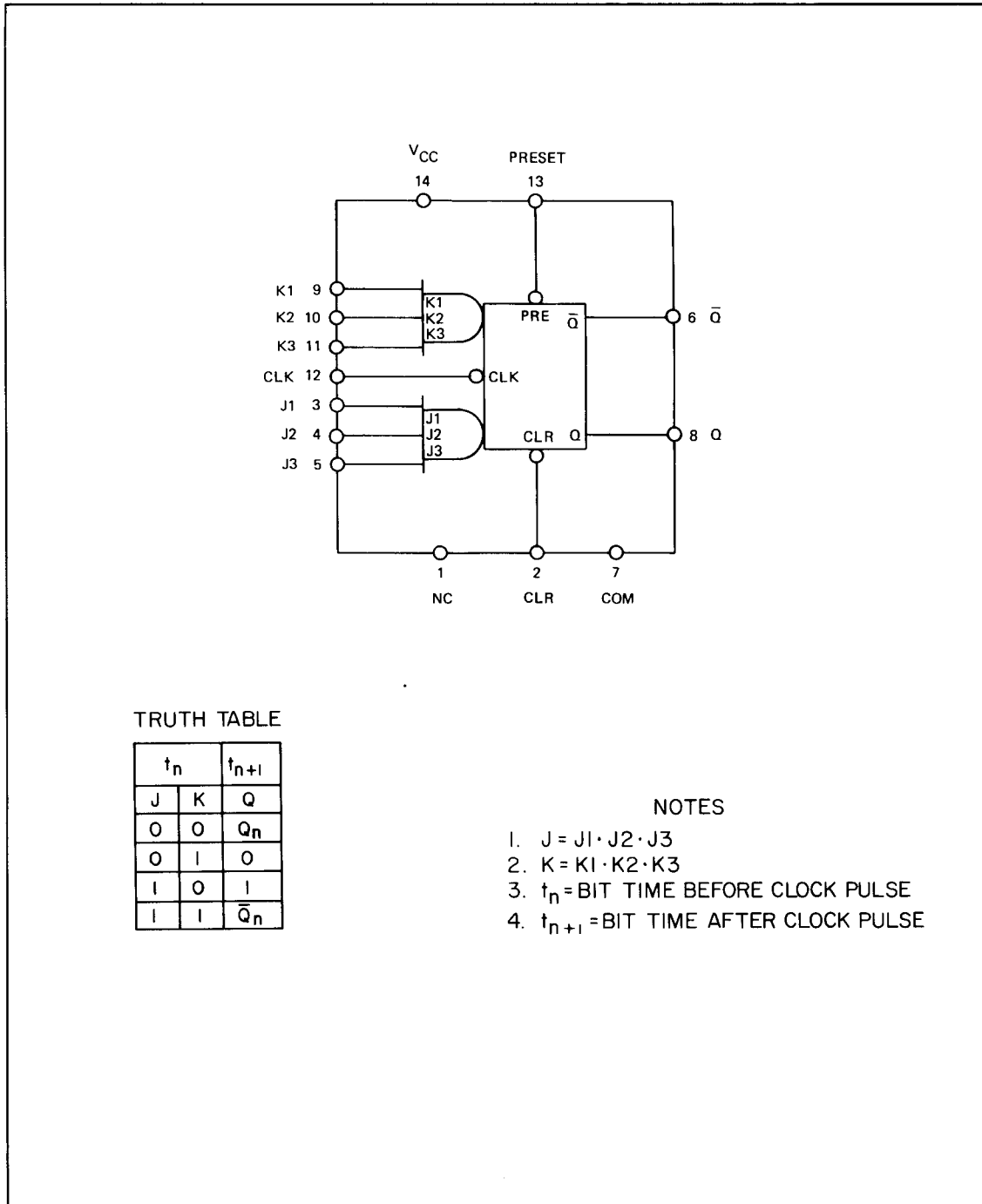

Figure 3-6. Operational Amplifier

**3-24. J-K Flip-Flop (1820-0304)**

3-25. Figure 3-7 shows the logic diagram and truth table for the 1820-0304 J-K flip-flop. The flip-flop is an edge-triggered type having direct clear and preset inputs. Input information will transfer to the outputs on the negative transition of the clock pulse. The J input is defined as  $J1 \bullet J2 \bullet J3$ . The K input is  $K1 \bullet K2 \bullet K3$ . When J and K are both low, the clock pulses have no effect. When J is high and K is low, the negative clock transition will set the flip-flop so that Q is high and  $\bar{Q}$  is low. When K is high and J is low, the negative clock transition will reset the flip-flop so that Q is low and  $\bar{Q}$  is high. If both J and K are high, the flip-flop will change states (toggle) with each negative clock transition. A low input at pin 13 will preset the flip-flop (Q high) and a low input to pin 2 will clear the flip-flop ( $\bar{Q}$  high).



TRUTH TABLE

$t_n$		$t_{n+1}$
J	K	Q
0	0	$Q_n$
0	1	0
1	0	1
1	1	$\bar{Q}_n$

NOTES

1.  $J = J1 \cdot J2 \cdot J3$
2.  $K = K1 \cdot K2 \cdot K3$
3.  $t_n$  = BIT TIME BEFORE CLOCK PULSE
4.  $t_{n+1}$  = BIT TIME AFTER CLOCK PULSE

Figure 3-7. J-K Flip-Flop

**3-26. Quadruple 2-Input Nor Gate (1820-0328)**

3-27. Figure 3-8 shows the logic diagram and truth table for the 1820-0328. Operation of the individual NOR gates is described in Paragraph 3-15.

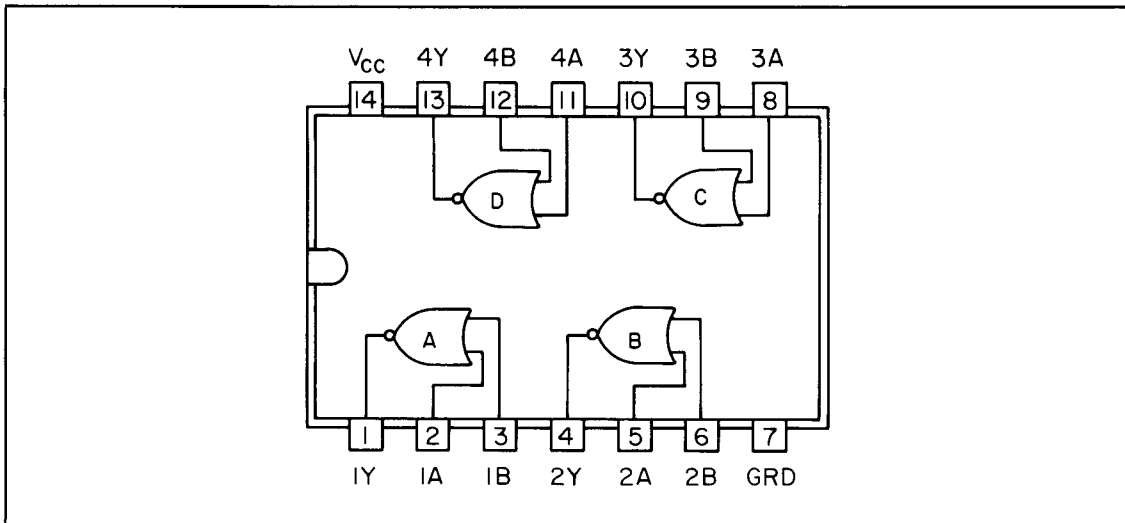

Figure 3-8. Quadruple 2-Input Nor Gate

**3-28. Dual Monostable Multivibrator (1820-0515)**

3-29. The dual multivibrator is shown in Figure 3-9. The units are retriggerable and resettable multivibrators which provide an output pulse whose duration is a function of the external timing components. The inputs are dc level sensitive; i.e., triggering occurs on the rising or trailing edges of the input waveform. Successive inputs with a period shorter than the delay time will retrigger the one-shot resulting in a continuous true output. The output pulse may be terminated at any time by applying a low logic level to the reset input.

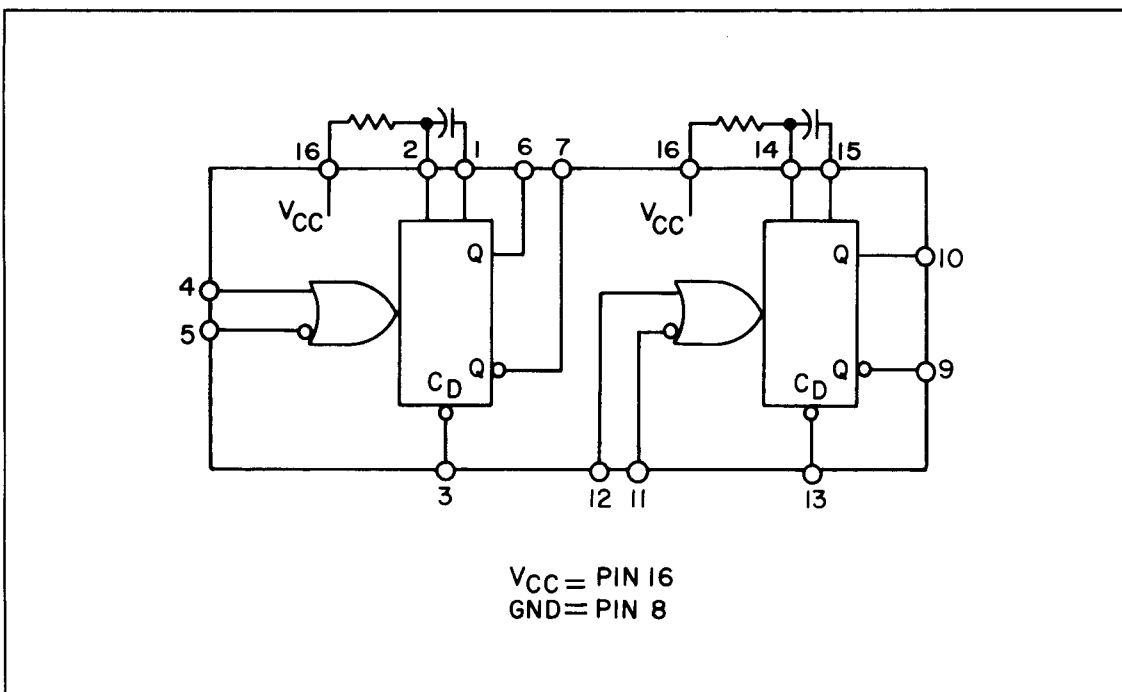

Figure 3-9. Dual Monostable Multivibrator

### 3-30. Dual Voltage-Controlled Multivibrator (1820-0567)

3-31. This multivibrator (Figure 3-10) is a voltage-controlled device which generates an output compatible with TTL circuitry. The output frequency is dependent on the input voltage and the size of an external capacitor connected between pins three and four or pins ten and eleven.

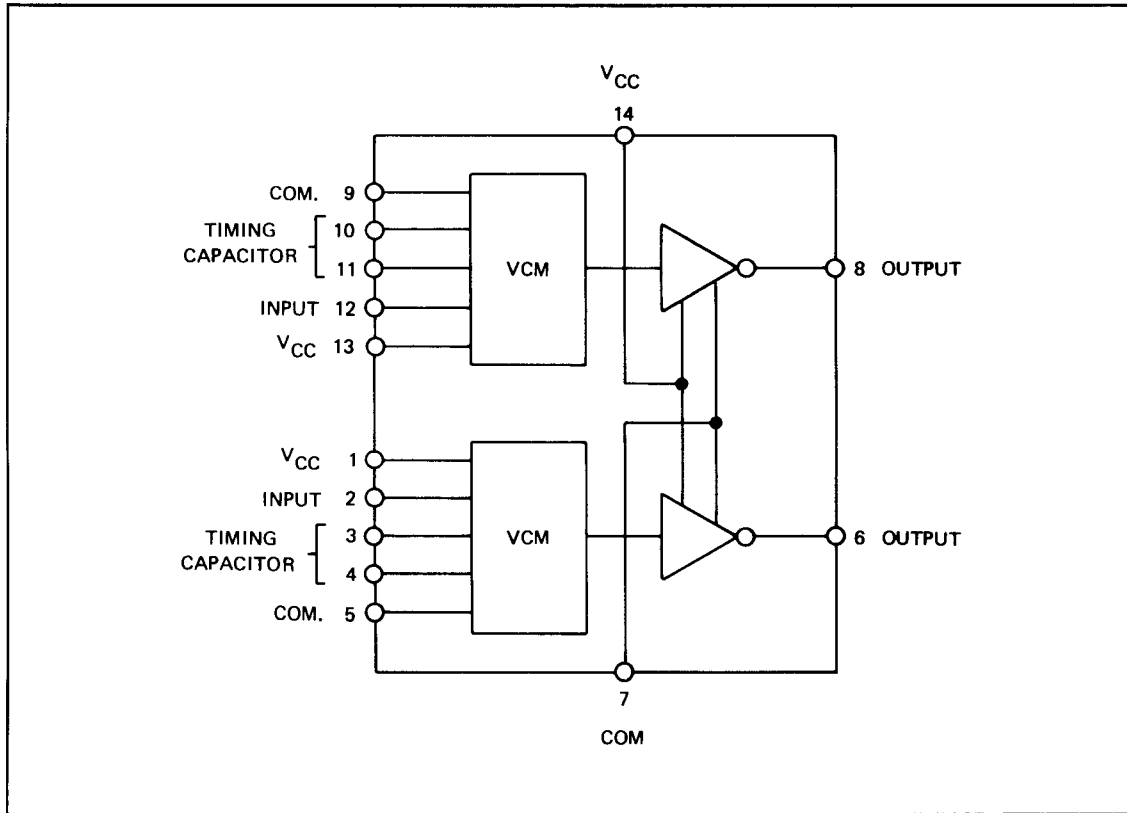

Figure 3-10. Dual Voltage-Controlled Multivibrator

### 3-32. Phase-Frequency Detector (1820-0630)

3-33. This device (Figure 3-11) contains two digital phase detectors and a charge pump circuit which converts TTL inputs to a dc voltage level. The two phase detectors have common inputs. Phase-frequency detector 1 is locked in (both outputs high) when the negative transitions of the variable input (V1) and the reference input (R1) are equal in frequency and phase. If the variable input is lower in frequency or lags in phase, the U1 output goes low; conversely, the D1 output goes low when the variable input is higher in frequency or leads the reference input in phase.

3-34. Phase detector 2 is locked in when the variable input phase lags the reference phase by 90° (indicated by U2 and D2 outputs alternately going low with equal pulse widths). If the variable input phase lags by more than 90°, U2 remains low longer than D2. If the variable input phase lags the reference phase by less than 90°, D2 remains low longer.

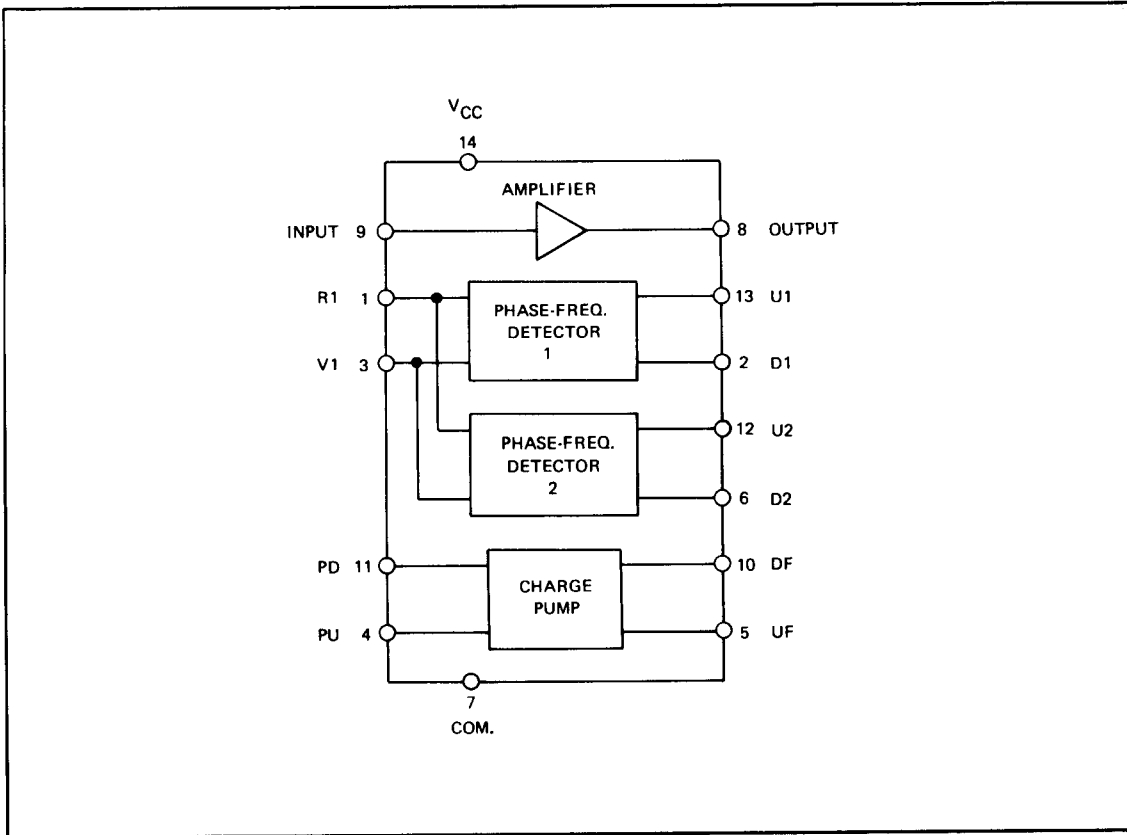

Figure 3-11. Phase-Frequency Detector

**3-35. Dual Differential Line Driver (1820-0720)**

3-36. Figure 3-12 shows the dual differential line driver. Each driver consists of a 4-input AND gate and an inverter. The differential outputs are balanced and designed to drive coaxial, strip-line, or twisted pair transmission lines with characteristic impedances of 50 to 500 ohms.

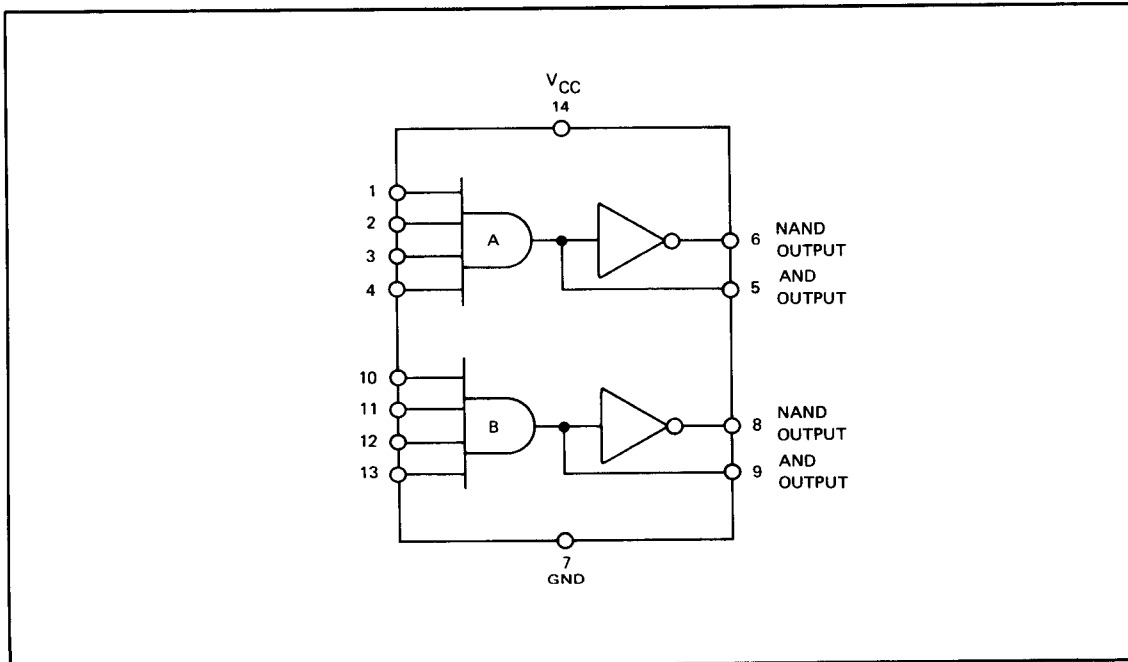

Figure 3-12. Dual Differential Line Driver

**3-37. Dual Line Receiver (1820-0721)**

3-38. The 1820-0721 Line Receiver (Figure 3-13) is used with digital systems connected by twisted pair lines. The output is compatible with RTL, DTL, or TTL. The output state is a logic 1 for both inputs open. Termination resistors for the twisted pair lines are included in the circuit.

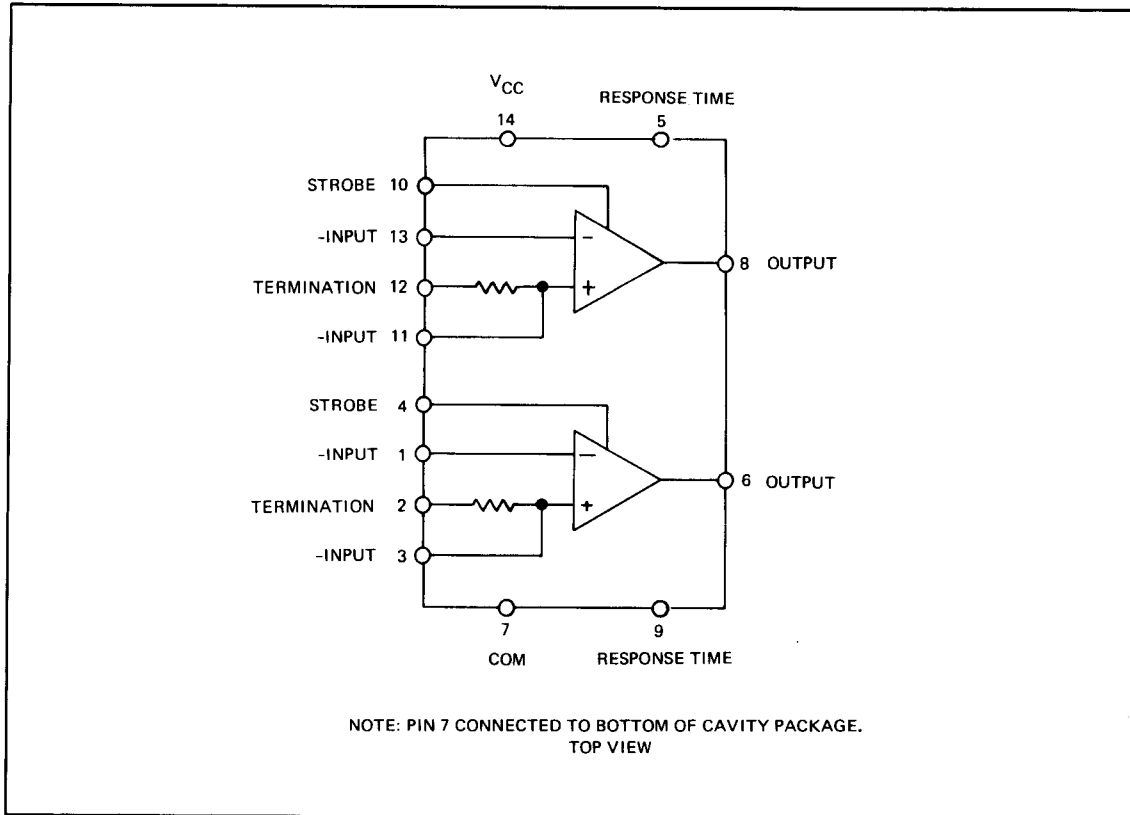

Figure 3-13. Dual Line Receiver

**3-39. Presettable Decade Counter/Latch (1820-0751)**

3-40. This IC (Figure 3-14) consists of four dc-coupled, master-slave flip-flops internally connected to provide a +2 and a +5 counter. The outputs may be preset to any state by driving the count/load input (pin 1) low and entering data at the data input lines. The outputs will follow the inputs independent of the clock. The counter can also be used as four-bit latches by using pin 1 as the strobe and entering data on the data inputs. In this mode, the outputs will follow the inputs when pin 1 is low, but will remain unchanged (latched) when pin 1 is high and the clock is inactive. The counters accept 0 to 50 MHz at the clock 1 input and 0 to 25 MHz at the clock 2 input. During the count operation, transfer of information to the outputs occurs on the negative-going edge of the clock pulse. When the clear input is driven low, all outputs go low regardless of the clock states.

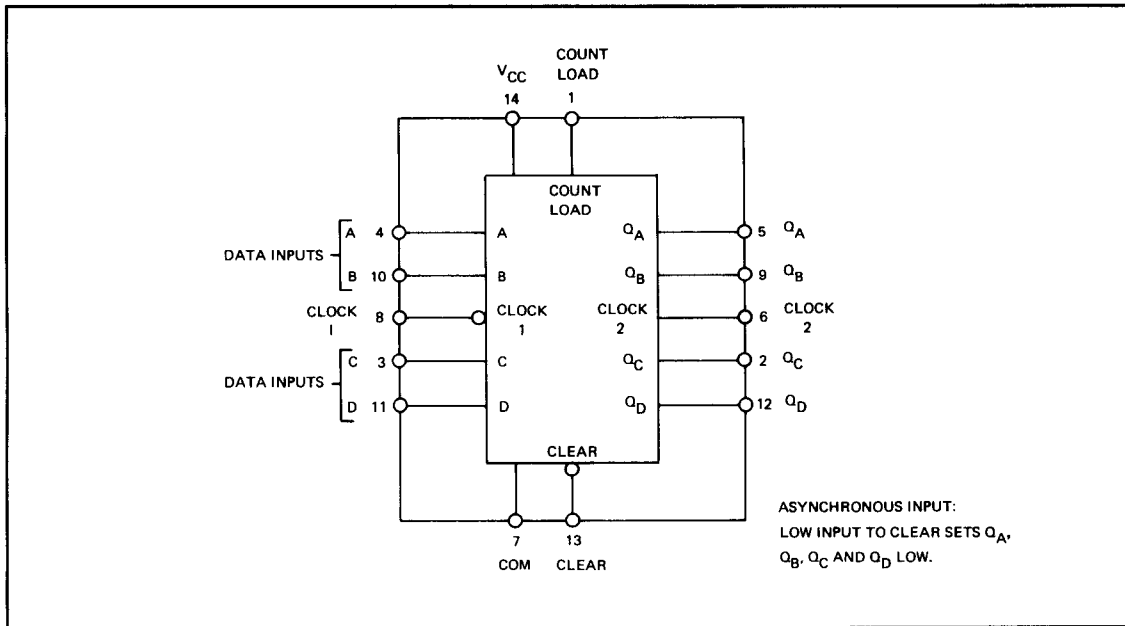

Figure 3-14. Presettable Decade Counter/Latch

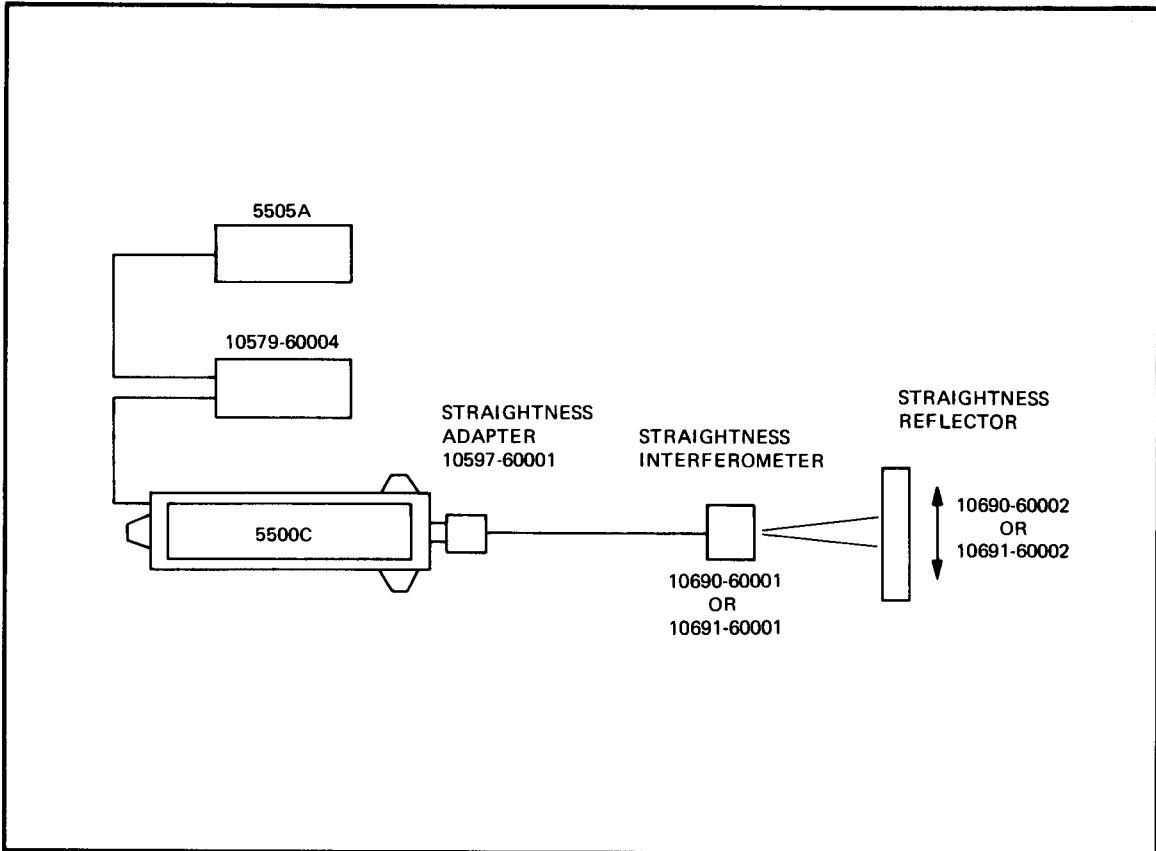

Figure 4-1. Functional Test With Straightness Optics

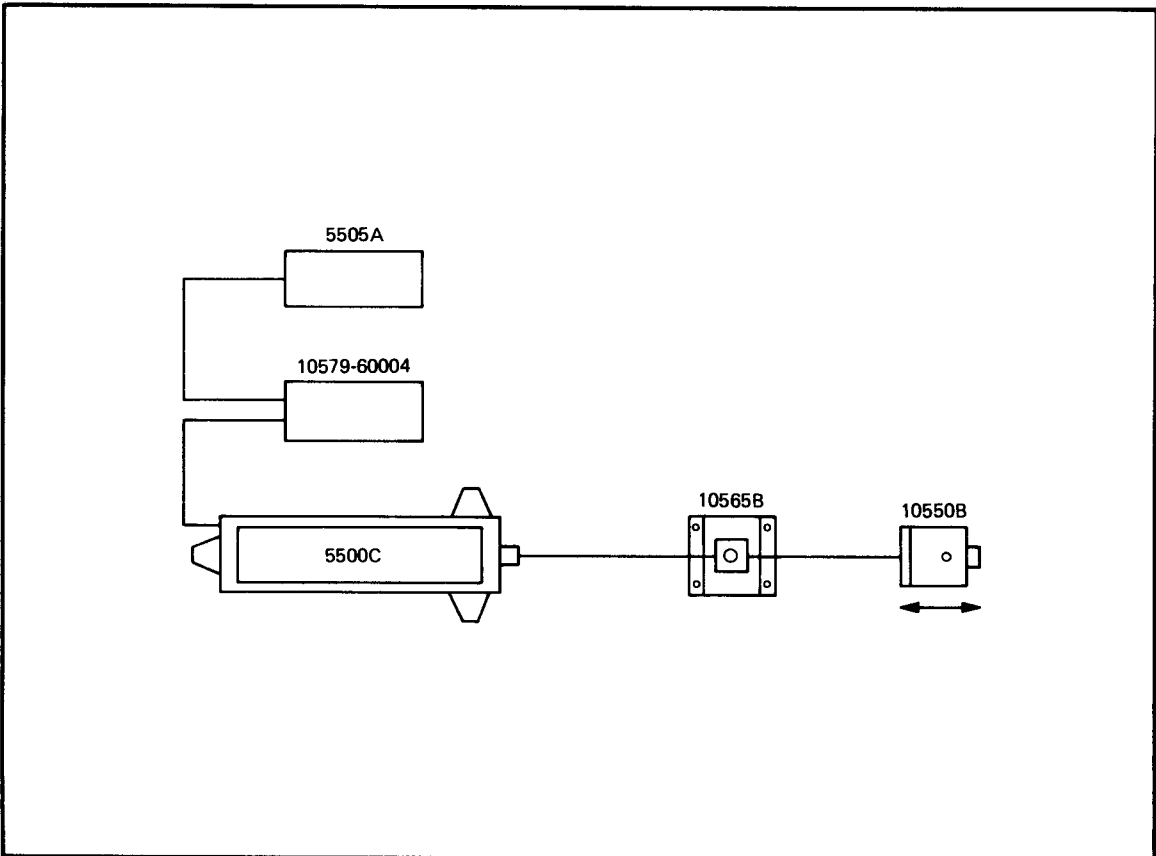

Figure 4-2. Functional Test With Distance Optics



## SECTION IV MAINTENANCE

### 4-1. INTRODUCTION

4-2. This section contains maintenance and service information. It includes a table of recommended test equipment, functional checks, an adjustment procedure, a troubleshooting procedure, and schematic diagrams.

### 4-3. TEST EQUIPMENT

4-4. Table 4-1 lists the test equipment recommended for maintaining the 10579-60004 Resolution Extender. Test equipment having equivalent characteristics may be substituted for the items listed. If the adjustments are made while the unit is connected to a 5526A Laser Measurement System, only the frequency counter is required. If adjustments are to be made on the 10579-60004 alone, then all items in Table 4-1 are required.

Table 4-1. Recommended Test Equipment

Instrument	Required Characteristics	Recommended Type
Oscilloscope	7 MHz bandpass; 5 mV to 20V vertical deflection	HP 1217A
Power Supply	Dual dc Power Supply 0—20V; 0.6A	HP 6205B
Function Generator	0.0005 Hz to 5 MHz; dc offset	HP 3310A
Universal Timer/Counter/DVM	50 MHz	HP 5326B

### 4-5. FUNCTIONAL CHECKS

4-6. Functional checks for the 10579-60004 Resolution Extender can be performed with a straightness measuring optical setup (Figure 4-1) or with a distance measuring optical setup (Figure 4-2). Either technique will verify normal operation in both the STRAIGHTNESS and DISTANCE modes. The fastest check procedure would normally be to use an existing optical setup. However, if neither setup is available, the distance measuring optical system is less critical and it can be set up in less time.

### 4-7. Functional Check with Straightness Measuring Optics

4-8. Perform the following steps to verify normal operation of the 10579-60004 Resolution Extender.

- a. Complete the installation procedure described in Section II of this handbook supplement, and the optical system alignment described in the Operator's Handbook Supplement.
- b. Press 5505A Laser Display NORMAL switch and set UNITS switch to "in".
- c. Set 10579-60004 Resolution Extender switch to DISTANCE (NORMAL) position.
- d. Press RESET switch on the 5505A Laser Display.
- e. Using manual or programmed control, move the Straightness Interferometer laterally 0.036 inches.
- f. Verify that the display indicates approximately 0.001 inches (for short range interferometer), or 0.0001 inches (for long range interferometer), and note the sign.
- g. Set 10579-60004 Resolution Extender switch to STRAIGHTNESS (EXTENDED) and press RESET switch on the display.

- h. Return the Straightness Reflector to its original position and verify that the display indicates approximately 0.036 inches. The sign of the display will be the opposite of the sign noted in step f. If abnormal indications are obtained, refer to the adjustment procedure.

#### 4-9. Functional Check With Distance Measuring Optics

4-10. Perform the following steps to verify normal operation of the 10579-60004 Resolution Extender.

- a. Complete the installation procedure described in Section II of this handbook supplement.
- b. Align 10565B Remote Interferometer and 10550B Reflector Mount so that the returned beam enters the lower aperture of the laser head turret.
- c. On the 5505A Laser Display, press NORMAL switch and set UNITS switch to "in".
- d. Set 10579-60004 Resolution Extender switch to DISTANCE (NORMAL) position.
- e. Press RESET switch on the 5505A Laser Display, and note initial position of the Reflector Mount.
- f. Move Reflector Mount longitudinally for a distance of approximately 1 inch, and verify that the display indicates approximately 1 inch.
- g. Set 10579-60004 Resolution Extender switch to STRAIGHTNESS (EXTENDED) and press RESET switch on the display.
- h. Slowly (less than 0.33 inches/second) return the reflector mount to its initial position, and verify that the display indicates approximately 36 inches. If abnormal indications are obtained, refer to the adjustment procedure.

#### 4-11. ADJUSTMENT PROCEDURE

4-12. There are two adjustable components in the 10579-60004 Resolution Extender, and two procedures are provided for making the adjustments. The first procedure is used when the extender is connected to the 5526A Laser Measurement System; it requires only a frequency counter for completion. The second procedure is used when the entire laser measurement system is not available, and it requires all of the test equipment listed in Table 4-1.

#### 4-13. Adjustment with 5526A Laser Measurement System

4-14. Use the following procedure.

- a. Connect the 10579-60004 Resolution Extender to the laser measurement system (refer to Installation procedure in Section II of this handbook supplement).
- b. Using any available optical setup, align optical system to return laser beam to one of the Display A apertures on the laser head turret. The BEAM ALIGNMENT meter on the 5505A Laser Display must be in the green range.
- c. Set front-panel switch on the 10579-60004 Resolution Extender to the STRAIGHTNESS (EXTENDED) position.
- d. Set 5326B Timer/Counter/DVM controls as follows:
  - (1) Function ..... Freq A
  - (2) Time Base ..... .1s
  - (3) Slope ..... +
  - (4) AC/DC ..... DC
  - (5) Atten ..... X1
  - (6) Level ..... Preset
  - (7) CHK/SEP/COM ..... SEP
- e. Connect 5326B A input channel to A1TP13 and common to COM.
- f. Connect a jumper wire between A1TP4 and A1TP COM.
- g. If needed, adjust "D" potentiometer R27 for a counter reading of 5 MHz or greater.
- h. Disconnect jumper wire from A1TP4 and connect it to A1TP8.
- i. Verify that counter reading is less than 100 kHz. If necessary, readjust "D" potentiometer R27 to get VCM minimum frequency down to 100 kHz. Then move jumper back to A1TP4 and verify that VCM maximum frequency is at least 5 MHz.

- j. Remove jumper wire.
- k. Move 5326B A input channel connection from A1TP13 to A1TP10.
- l. Adjust "F" potentiometer R2 for a counter reading of 2.5 MHz  $\pm$  10 kHz.

#### 4-15. Adjustment Without 5526A Laser Measurement System

4-16. Use the following procedure.

- a. Set one section of the 6205B Dual Dc Power Supply to +5V and connect positive side to Pin C of either rear-panel connector. Connect negative side to Pin A or L of either rear-panel connector.
- b. Set second section of the 6205B Dual Dc Power Supply to +15V and connect positive side to Pin T of either rear-panel connector. Connect negative side to pin A or L of either rear-panel connector.
- c. Set 3310A Function Generator controls as follows:
  - (1) Range ..... 100k
  - (2) Function ..... SQ
  - (3) DC Offset ..... +
- d. Connect the 3310A HIGH output to the 1217A Oscilloscope vertical input.
- e. Adjust the 3310A Function Generator controls for the following output:
  - (1) Output Frequency ..... 2 MHz  $\pm$  1 kHz
  - (2) Output Level ..... 3.5V P-P
  - (3) DC Offset ..... 0V
- f. Disconnect function generator HIGH output from the oscilloscope and connect it to A1TP1 and A1TP5. Connect common lead to A1TP COM.
- g. Complete adjustment steps "e" through "l" of Paragraph 2-14.

#### 4-17. TROUBLESHOOTING

4-18. The troubleshooting procedure for the 10579-60004 Resolution Extender is contained in Figure 4-3. Troubleshooting may be performed by using the adjustment procedure step in Paragraphs 4-13 and 4-14, or by using the setup in Paragraphs 4-15 and 4-16.

4-19. The frequencies listed in the troubleshooting procedure are based upon a split frequency<sup>1</sup> of 2 MHz. If the adjustment setup listed in Paragraphs 4-15 and 4-16 is used, the measured frequencies will be close to those listed. If the troubleshooting is performed while the 10579-60004 Resolution Extender is connected to a 5526A Laser Measurement System, the measured frequencies may differ by as much as 25 percent.

4-20. Figure 4-4 provides a schematic diagram and a component locator diagram for A1, the 10597-60005 Frequency Multiplier Assembly. Figure 4-5 provides a schematic diagram of A2, the 10579-60006 Rear-Panel Connector Assembly.

---

<sup>1</sup>The split frequency for an individual laser head may be anywhere in the range of 1.5 MHz to 2.5 MHz. Refer to the discussion of 5500C Laser Head Principles in the 5526A Laser Measurement System Service Manual for a brief description of Zeeman splitting.



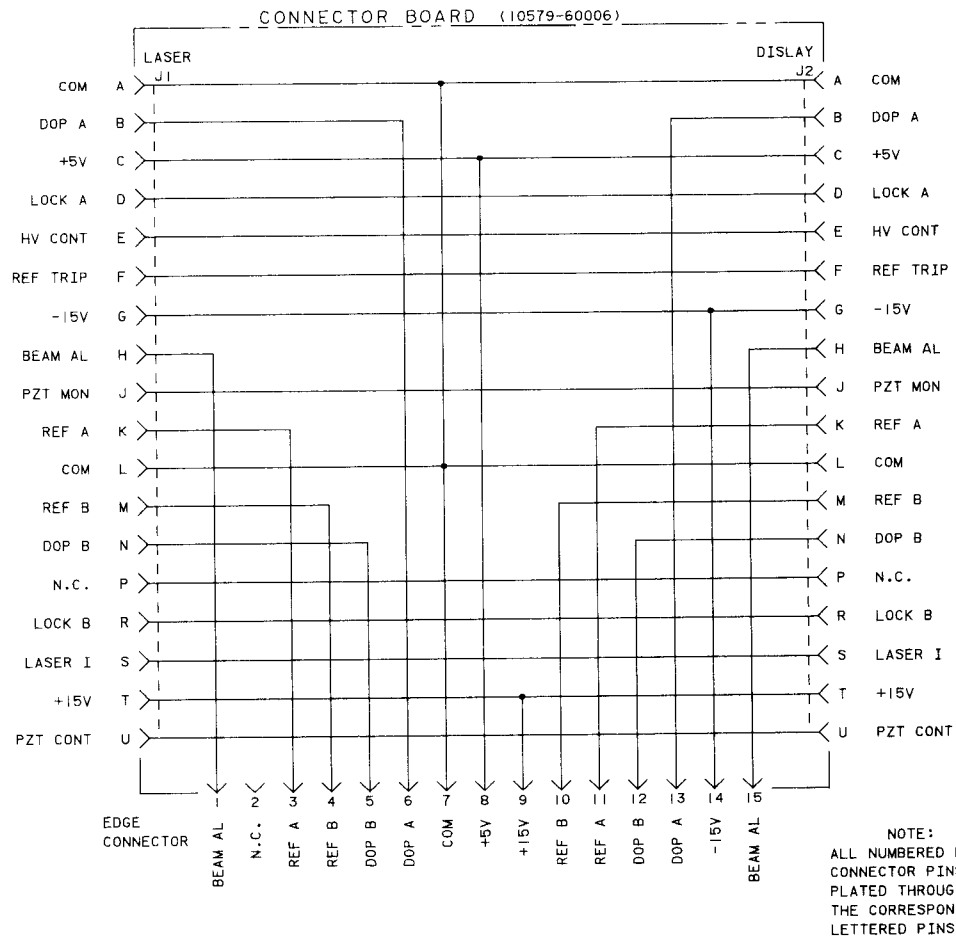

Figure 4-5. Rear Panel Connector Assembly Schematic Diagram

## **SECTION V**

### **REPLACEABLE PARTS**

#### **5-1. INTRODUCTION**

5-2. This section contains information for ordering replaceable parts. Table 5-1 lists replaceable parts for the standard instrument. Table 5-2 contains a list of manufacturers and their codes.

5-3. Parts are listed in alpha-numerical order of their reference designator starting with A1 and ending with chassis and miscellaneous parts. The replaceable parts table includes the following information.

- a. Reference designator (when applicable).
- b. HP Part number.
- c. Total quantity (Qty) used in the instrument (listed at first entry).
- d. Description of the part.
- e. Typical manufacturer of the part in a five-digit code; see list of manufacturers in Table 5-2.
- f. Manufacturer's part number.

#### **5-4. ORDERING INFORMATION**

5-5. To obtain replacement parts, address order or inquiry to your local Hewlett-Packard Sales and Service Office. Identify parts by their Hewlett-Packard part number.

5-6. To obtain a part that is not listed, include:

- a. Instrument model number.
- b. Instrument serial number.
- c. Description of the part.
- d. Function and location of the part.

Table 5-1. Replaceable Parts

Reference Designation	HP Part Number	Qty	Description	Mfr Code	Mfr Part Number	
A1	10579-60005	1	BOARD ASSY:FREQUENCY MULTIPLIER	28480	10579-60005	
A1C1	0160-0174	7	CAPACITOR,FXD, .47UF+80-20% 25WVDC	28480	0160-0174	
A1C2	0160-0174		CAPACITOR,FXD, .47UF+80-20% 25WVDC	28480	0160-0174	
A1C3	0160-0174		CAPACITOR,FXD, .47UF+80-20% 25WVDC	28480	0160-0174	
A1C4	0160-0174		CAPACITOR,FXD, .47UF+80-20% 25WVDC	28480	0160-0174	
A1C5	0160-0174		CAPACITOR,FXD, .47UF+80-20% 25WVDC	28480	0160-0174	
A1C6	0160-0174		CAPACITOR,FXD, .47UF+80-20% 25WVDC	28480	0160-0174	
A1C7	0160-0335		1	CAPACITOR,FXD, 91PF+-5% 300WVDC	72136	DM15E620J0300WV1CR
A1C8	0160-0182	2	CAPACITOR,FXD, 47PF+-5% 300WVDC	28480	0160-0182	
A1C9	0150-3060		CAPACITOR,FXD, .1UF+80-20% 50 WVDC	28480	0150-3060	
A1C10	0160-0182	1	CAPACITOR,FXD, 47PF+-5% 300WVDC	28480	0160-0182	
A1C11	0160-2327		CAPACITOR,FXD, .001UF+-20% 100WVDC	28480	0160-2327	
A1C12	0160-3277		4	CAPACITOR,FXD, .01UF+-20% 50WVDC	28480	0160-3277
A1C13	0160-0174		CAPACITOR,FXD, .47UF+80-20% 25WVDC	28480	0160-0174	
A1C14	0160-3277	1	CAPACITOR,FXD, .01UF+-20% 50WVDC	28480	0160-3277	
A1C15	0160-3277		CAPACITOR,FXD, .01UF+-20% 50WVDC	28480	0160-3277	
A1C16	0160-3277		CAPACITOR,FXD, .01UF+-20% 50WVDC	28480	0160-3277	
A1CR1	1902-3082		1	DIODE, VREG, 4.64V VZ, .4W MAX	28480	1902-3048
A1CR2	1901-0040	4	DIODE, SWITCHING, SI, 30V MAX VRM 50MA	28480	1901-0040	
A1CR3	0122-0066		1	DIODE-VVC, SI 00-14	28480	0122-0066
A1CR4	1901-0040		DIODE, SWITCHING, SI, 30V MAX VRM 50MA	28480	1901-0040	
A1CR5	1901-0040		DIODE, SWITCHING, SI, 30V MAX VRM 50MA	28480	1901-0040	
A1CR6	1901-0040		DIODE, SWITCHING, SI, 30V MAX VRM 50MA	28480	1901-0040	
A1L1	9140-0137		2	COIL, FXD, MOLDED RF CHOKE, 1 MH 5%	24226	19/104
A1L2	9140-0137	COIL, FXD, MOLDED RF CHOKE, 1MH 5%		24226	19/104	
A1Q1	1854-0215	2	TRANSISTOR, NPN SI	04713	SPS 3611	
A1Q2	1854-0215		TRANSISTOR, NPN SI	04713	SPS 3611	
A1R1	0683-2015	1	RESISTOR, FXD, 200 OHMS% .25W CC	01121	CB2015	
A1R2	2100-1775	2	RESISTOR, VAR, TRMR, 5KOHM 5% MW	28480	2100-1775	
A1R3	0683-1025	7	RESISTOR, FXD, 1K5% .25W CC TUBULAR	01121	CB1025	
A1R4	0683-1025		RESISTOR, FXD, 1K5% .25W CC TUBULAR	01121	CB1025	
A1R5	0683-1025		RESISTOR, FXD, 1K5% .25W CC TUBULAR	01121	CB1025	
A1R6	0683-1025		RESISTOR, FXD, 1K5% .25W CC TUBULAR	01121	CB1025	
A1R7	0683-1025		RESISTOR, FXD, 1K5% .25W CC TUBULAR	01121	CB1025	
A1R8	0683-1025		RESISTOR, FXD, 1K5% .25W CC TUBULAR	01121	CB1025	
A1R9	0683-5125		3	RESISTOR, FXD, 5.1K5% .25W CC TUBULAR	01121	CB5125
A1R10	0683-5135	1	RESISTOR, FXD, 51K5% .25W CC TUBULAR	01121	CB5135	
A1R11	0683-1635	1	RESISTOR, FXD, 16K5% .25W CC TUBULAR	01121	CB1635	
A1R12	0683-1025	RESISTOR, FXD, 1K5% .25W CC TUBULAR	01121	CB1025		
A1R13	0683-8225	1	RESISTOR, FXD, 8.2K5% .25W CC TUBULAR	01121	CB8225	
A1R14	0683-2725	1	RESISTOR, FXD, 2.7K5% .25W CC TUBULAR	01121	CB2725	
A1R15	0683-4725	2	RESISTOR, FXD, 4.7K5% .25W CC TUBULAR	01121	CB4725	
A1R16	0683-3935	3	RESISTOR, FXD, 39K5% .25W CC TUBULAR	01121	CB3935	
A1R17	0683-5125		RESISTOR, FXD, 5.1K5% .25W CC TUBULAR	01121	CB5125	
A1R18	0683-1035	2	RESISTOR, FXD, 10K5% .25W CC TUBULAR	01121	CB1035	
A1R19	0683-1035		RESISTOR, FXD, 10K5% .25W CC TUBULAR	01121	CB1035	
A1R20	0683-4725		RESISTOR, FXD, 4.7K5% .25W CC TUBULAR	01121	CB4725	
A1R21	0683-6825		1	RESISTOR, FXD, 6.8K5% .25W CC TUBULAR	01121	CB6825
A1R22	0683-3935	RESISTOR, FXD, 39K5% .25W CC TUBULAR	01121	CB3935		
A1R23	0683-6835	1	RESISTOR, FXD, 68K5% .25W CC TUBULAR	01121	CB6835	
A1R24	0683-5125	1	RESISTOR, FXD, 5.1K5% .25W CC TUBULAR	01121	CB5125	
A1R25	0683-3015		RESISTOR, FXD, 300 OHMS% .25W CC	01121	CB3015	
A1R26	0683-3935		RESISTOR, FXD, 39K5% .25W CC TUBULAR	01121	CB3935	
A1R27	2100-1775		RESISTOR, VAR, TRMR, 5KOHM 5% MW	28480	2100-1775	
A1S1	3101-0630		1	SWITCH:TOGGLE DPDT 0.4 VA	09353	7201-AV2-PH
A1U1	1820-0077	6	INTEGRATED CIRCUIT, DGTL, TTL DUAL D	01295	SN7474N	
A1U2	1820-0751		INTEGRATED CIRCUIT, DGTL, TTL DECADE	01295	SN74196N	
A1U3	1820-0515	1	INTEGRATED CIRCUIT, DGTL, TTL DUAL RE	07263	U68960259X	
A1U4	1820-0751		INTEGRATED CIRCUIT, DGTL, TTL DECADE	01295	SN74196N	
A1U5	1820-0077	1	INTEGRATED CIRCUIT, DGTL, TTL DUAL D	01295	SN7474N	
A1U6	1820-0216		INTEGRATED CIRCUIT, LIN, OP AMPL	28480	1820-0216	
A1U7	1820-0630		INTEGRATED CIRCUIT, DGTL, TTL	04713	MC4044P	
A1U8	1820-0567		INTEGRATED CIRCUIT, DGTL, TTL DUAL	04713	MC4024P	
A1U9	1820-0304		INTEGRATED CIRCUIT, DGTL, TTL J-K M/S	01295	SN7472N	
A1U10	1820-0054		2	INTEGRATED CIRCUIT, DGTL, TTL QUAD 2	01295	SN7400N
A1U11	1820-0054			INTEGRATED CIRCUIT, DGTL, TTL QUAD 2	01295	SN7400N
A1U12	1820-0720		1	INTEGRATED CIRCUIT, DGTL, TTL DUAL	27014	DM8830N
A1U13	1820-0077		1	INTEGRATED CIRCUIT, DGTL, TTL DUAL D	01295	SN7474N
A1U14	1820-0077	INTEGRATED CIRCUIT, DGTL, TTL DUAL D		01295	SN7474N	
A1U15	1820-0328	1	INTEGRATED CIRCUIT, DGTL, TTL QUAD 2	01295	SN7402N	
A1U16	1820-0077		INTEGRATED CIRCUIT, DGTL, TTL DUAL D	01295	SN7474N	
A1U17	1820-0077		INTEGRATED CIRCUIT, DGTL, TTL DUAL D	01295	SN7474N	
A1U18	1820-0721		1	INTEGRATED CIRCUIT, DGTL, TTL DUAL DIFF	27014	DM8820AN
	0360-0124	14	TERMINAL:SGOLDER LUG	28480	0360-0124	

See introduction to this section for ordering information

Table 5-1. Replaceable Parts (Cont'd)

Reference Designation	HP Part Number	Qty	Description	Mfr Code	Mfr Part Number
A2	1251-2035	1	CONNECTOR, PC EDGE, 15-CONT, DIP SOLDER	71785	252-15-30-300
	10579-60006	1	BCARD ASSY:CCNECTOR	28480	10579-60006
	0380-0310	2	STANDOFF, ROUND, FEMALE, .75 L	00866	19218
	0380-0896	8	RIVET-ON STANDOFF, 4-40, .438 LG, .062	28480	0380-0896
	1251-3140	2	CONNECTOR:CIRCULAR	28480	1251-3140
	10579-00003	1	BRACKET	28480	10579-00003
	10579-60001	1	ADAPTER ASSY:STRAIGHTNESS	28480	10579-60001
	0400-0002	4	GROMMET	28480	0400-0002
	1000-0309	1	PLANE REFLECTOR	28480	1000-0309
	1000-0310	1	BEAM SPLITTER	28480	1000-0310
	10579-00004	1	COVER:BEAM DISPLAY	28480	10579-00004
	10579-20001	4	MOUNT:SCREW	28480	10579-20001
	10579-20002	1	MOUNT:ADAPTER	28480	10579-20002
	10579-80001	1	NAMEPLATE:SERIAL	28480	10579-80001
	10579-80002	1	NAMEPLATE:SYMBOL	28480	10579-80002
	2360-0220	2	SCREW # 6, 2 1/4 INCH	28480	2360-0220
	10579-60004	1	EXTENDER ASSY:X36 RESOLUTION	28480	10579-60004
	2420-0022	6	NUT:PRESS-ON 6-32 X 0.354" OD	00000	08D
	2510-0195	4	SCREW,MACHINE, 8-32 UNC-2A .25 IN ROUND	28480	2510-0199
	5001-0438	2	TRIM:SIDE	28480	5001-0438
	5020-8823	1	FRAME:FRONT	28480	5020-8823
	5040-7204	1	TRIM:TOP	28480	5040-7204
	5040-7205	2	FOOT:1/4"	28480	5040-7205
	5040-7210	1	COVER:TOP	28480	5040-7210
	5040-7211	1	COVER:BOTTOM	28480	5040-7211
	5040-7212	2	COVER:SIDES	28480	5040-7212
	10579-00001	1	PANEL:FRONT	28480	10579-00001
	10579-00002	1	PANEL:REAR	28480	10579-00002

See introduction to this section for ordering information



Table 5-2. Manufacturers Code List

MFR. NO.	MANUFACTURER NAME	ADDRESS	ZIP CODE
00000	U.S.A. Common	Any supplier of U.S.A.	
00866	GOE Engineering Co., Inc.	City of Industry, Calif.	91746
01121	Allen Bradley Co.	Milwaukee, Wis.	53204
01295	Texas Instruments Inc. Semiconductor Components Div.	Dallas, Tex.	75231
04713	Motorola Semiconductor Prod. Inc.	Phoenix, Ariz.	85008
07263	Fairchild Camera & Inst. Corp. Semiconductor Div.	Mountain View, Calif.	94040
09353	C & K Components Inc.	Newton, Mass.	02158
24226	Gowanda Electronics Corp.	Gowanda, N.Y.	14070
27014	National Semi-conductor Corp.	Santa Clara, Calif.	95051
28480	Hewlett-Packard Co. Corporate Hq.	Your nearest HP office	
71785	Cinch Mfg. Co. Div. T.R.W. Inc.	Elk Grove Village, Ill.	
72136	Electro Motive Mfg. Co. Inc.	Willimantic, Conn.	06226

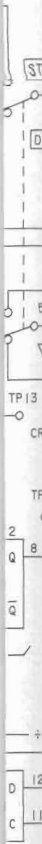
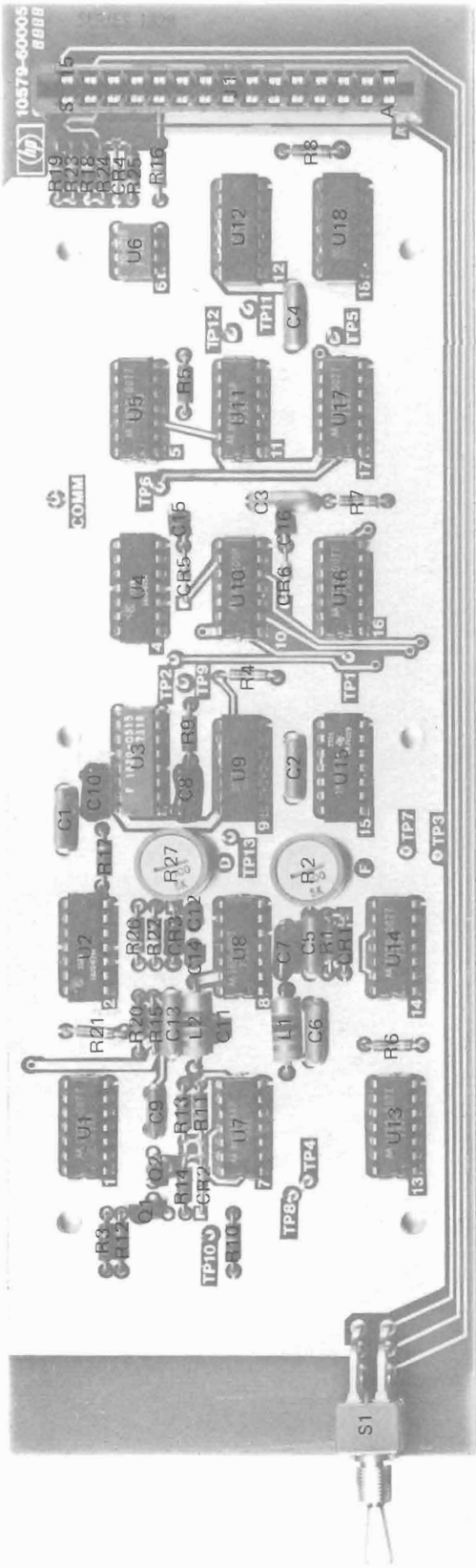

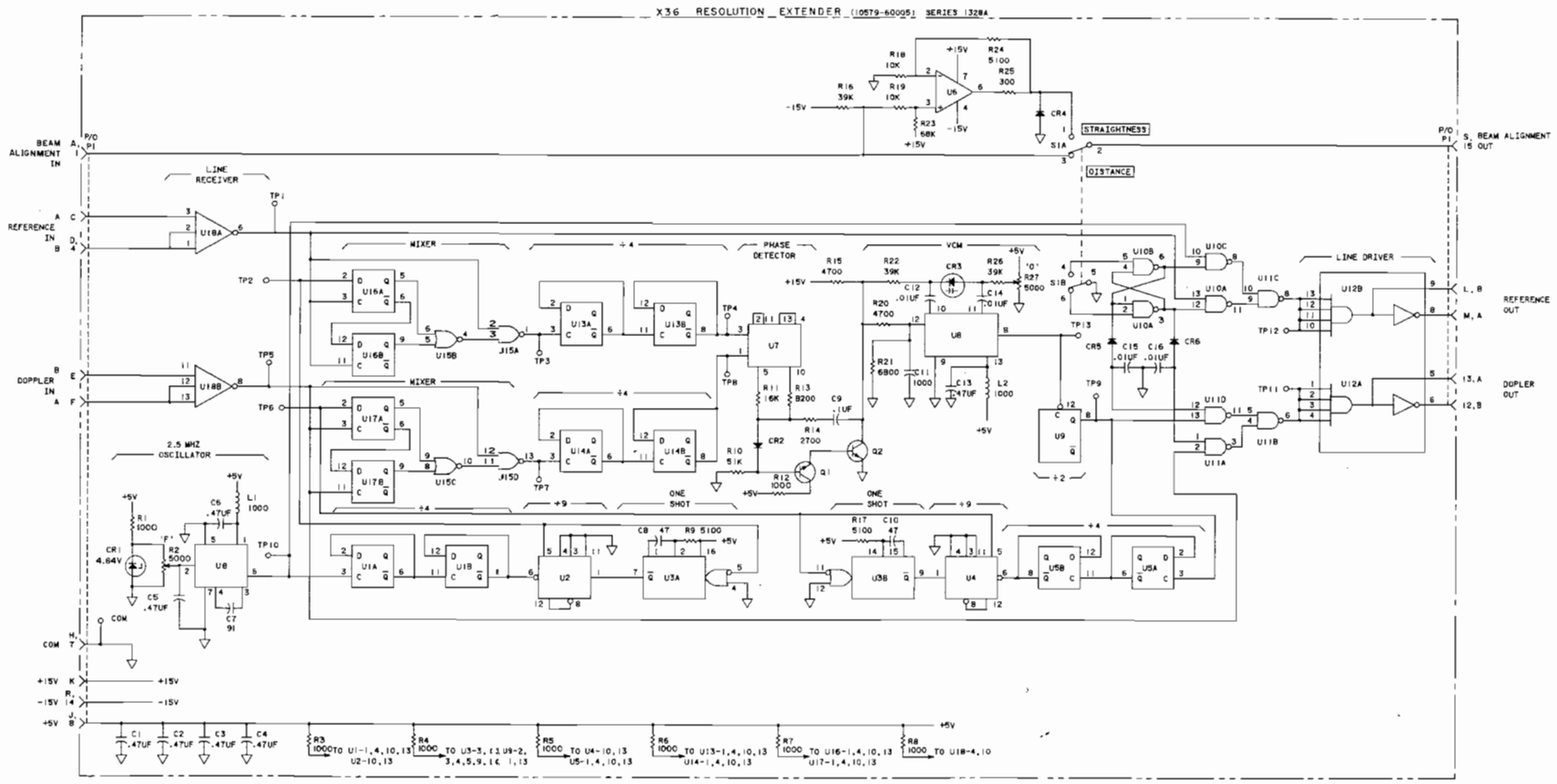

- NOTES**
1. REFERENCE DESIGNATIONS WITHIN THIS ASSEMBLY ARE ABREVIATED. ADD ASSEMBLY NUMBER TO ABBREVIATION FOR COMPLETE DESCRIPTION.
  2. UNLESS OTHERWISE INDICATED: RESISTANCE IN OHMS; CAPACITANCE IN PICOGRAMS; INDUCTANCE IN MICROHENRES.

**TABLE**

REFERENCE DESIGNATION	W/P PART NUMBER
CR1	1800-3048
CR2, 4, 6	1800-3049
CR3	0123-0088
Q1, 2	1864-0216
U1, U2, U3, U7, U14, U16, U17	1800-0211
U3, U4	1800-0215
U5	1800-0218
U6	1800-0601
U7	1800-0987
U8	1800-0204
U10, U11	1800-0206
U12	1800-0120
U13	1800-0228
U18	1800-0211

**REFERENCE DESIGNATIONS**

A1	U1-18
	CR1-6
	L1, 2
	Q1, 2
	RF-27
	S1
	U1-18

Figure 4-4  
A1 FREQUENCY MULTIPLIER  
SCHEMATIC DIAGRAM

**MANUAL DESCRIPTION**

INSTRUMENT: 10579A, 10690A, 10691A (used in Options 030, 031, 032 of 5526A System.)  
 SERIAL PREFIX: 1328A (10579A)

DATE PRINTED: NOV 1973  
 HP PART NO: 05526-90021  
 MICROFICHE NO: 05526-90025

**CHANGE DATE** August 7, 1974  
 (This change supersedes all earlier dated changes)

- Make all changes listed as ERRATA.
- Check the following table for your instrument's serial prefix or serial number and make listed change(s) to manual.

IF YOUR INSTRUMENT HAS SERIAL PREFIX OR SERIAL NUMBER	MAKE THE FOLLOWING CHANGES TO YOUR MANUAL	IF YOUR INSTRUMENT HAS SERIAL PREFIX OR SERIAL NUMBER	MAKE THE FOLLOWING CHANGES TO YOUR MANUAL
1420A	1		
▶1432A	1,2		

▶ **NEW OR REVISED ITEM**

**ERRATA**

Page 4-5, Figure 4-4, A1 FREQUENCY MULTIPLIER SCHEMATIC:

Change A1R1 from 1000 to 100 OHM.

Page 5-2, Table 5-1:

Change A1R1 from 0683-2015 to 0683-1015 100 OHM; MFR PART NO. CB1015.

**CHANGE 1 ( 1420A) See Note)**

Change A1U14 from 1820-0077 to 1820-0765; change description to: "IC:DGTL COUNTER".

Add A1C17 0160-3277 C:FXD .01 UF 20% 50WVDC

Add A1CR7 1901-0040 DIODE SWITCHING 30V MAX VRM 50 MA

Add A1Q3 1854-0215 TRANSISTOR: NPN SIL

Add A1R28 0683-1035 RESISTOR: FXD 10K OHM 5% 1/4W

Add A1R29, 30 0683-1315 RESISTOR: FXD 130 OHM 5% 1/4W

Add A1U19 1820-0077 IC: 7474

Add A1U20 1820-0065 IC: DGTL FF

With this change 10579-60005 board is SERIES 1420A. See attached schematic.

**NOTE**

The following non-consecutive serial numbers will have the above change: 1420A00102, 00105, 00106, 00107, 00110, 00111, 00112, 00114, 00115, 00116, 00118 and 00119.

▶ **CHANGE 2 (1432A)**

Page 5-2, Table 5-1:

Add A1R31 0683-1025 R: FXD 1000 OHM 5% 1/4W.

Page 4-5, Figure 4-4:

Add A1R31 1000 OHM as shown in attached schematic.

X36 RESOLUTION EXTENDER (10979-60009) SERIES 1432A AND 1420A (NOTE 3)

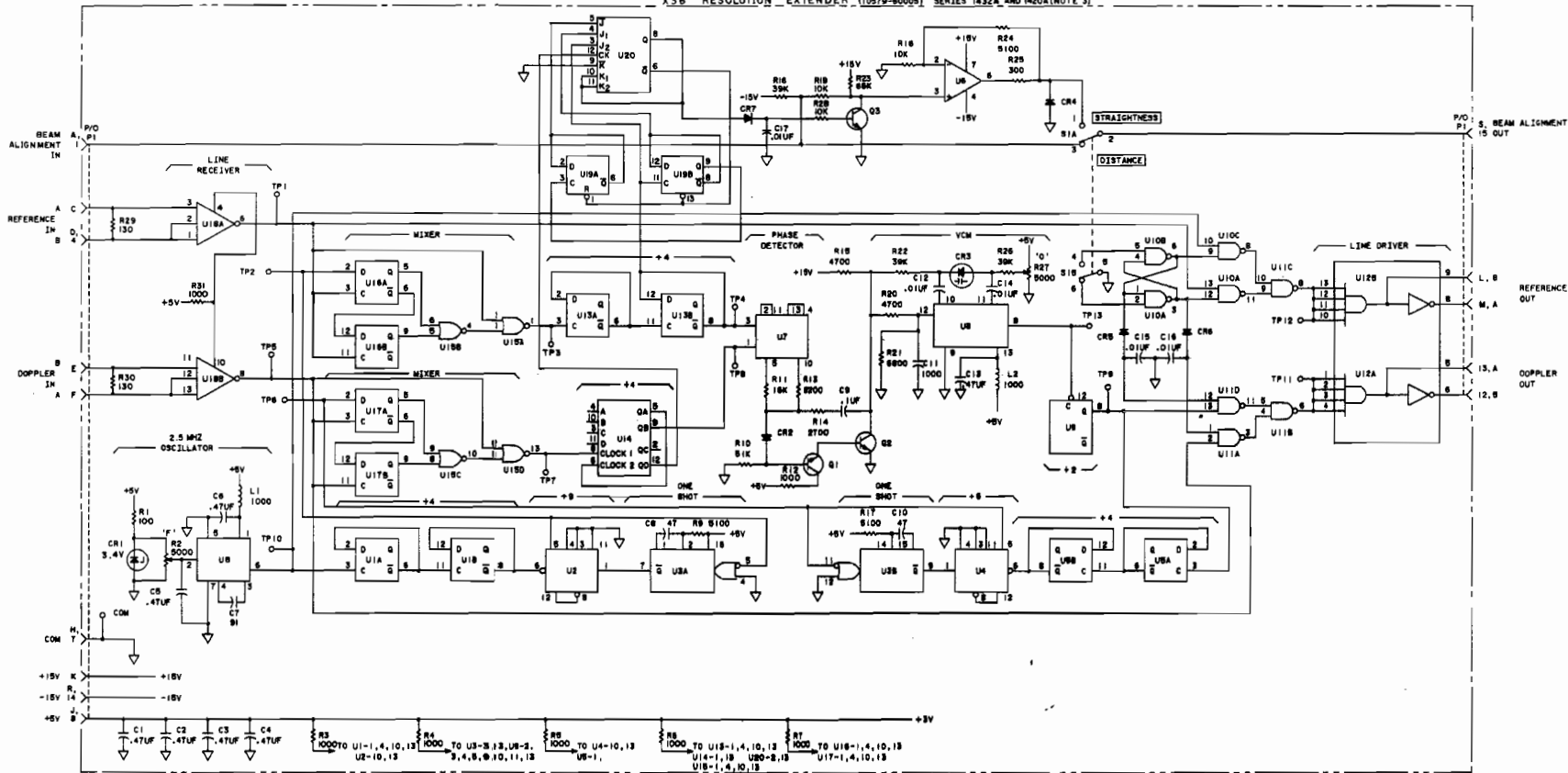

- NOTES
1. REFERENCE DESIGNATIONS WITHIN THIS ASSEMBLY ARE ABBREVIATED. ADD ASSEMBLY NUMBER TO ABBREVIATION FOR COMPLETE DESCRIPTION.
  2. UNLESS OTHERWISE INDICATED: RESISTANCE IN OHMS; CAPACITANCE IN PICO-FARADS; INDUCTANCE IN MICROHENRIES.
  3. X36 RESOLUTION EXTENDER ASSEMBLIES WITH SERIES 1420A DO NOT CONTAIN R31 AND CONNECTIONS TO U18A, (D).

TABLE

REFERENCE DESIGNATIONS	PART NUMBER
CR1	1820-3802
CR2, 4-7	1801-0040
CR3	0122-0066
CI 1, 2, 3	1884-0216
U1, U6, U13, U18, U17, U18	1830-0077
U2, U4	1820-0181
U3	1820-0218
U5	1820-0218
U7	1820-0202
U8	1820-0267
U9	1820-0264
U10, U11	1820-0264
U12	1820-0730
U14	1820-0788
U15	1820-0098
U16	1820-0731
U20	1820-0088

REFERENCE DESIGNATIONS

A1
CI-17
CR1-7
CI 2, 3
R1-R31
R1
U1-20

R8 NOT USED

C1 .47UF  
 C2 .47UF  
 C3 .47UF  
 C4 .47UF  
 R3 1000 TO U1-1, 4, 10, 13  
 U1-10, 13  
 R4 1000 TO U5-8, 13, U6-2, U14-1, 18  
 U6-1, 18  
 U14-1, 18  
 U20-8, 13  
 U17-1, 4, 10, 13  
 R5 1000 TO U4-10, 13  
 U4-10, 13  
 R6 1000 TO U15-1, 4, 10, 13  
 U15-1, 4, 10, 13  
 R7 1000 TO U16-1, 4, 10, 13  
 U16-1, 4, 10, 13